



808
808i

**SIGNATURE
REFERENCE
CD PLAYER**

USER GUIDE



**Meridian 808/808i Signature Reference
CD Player User Guide**



Important safety instructions

- Read the instructions.
- Keep these instructions.
- Follow all instructions.
- Do not use this apparatus near water.
- Clean only with a dry cloth.
- Install only in accordance with the manufacturer's instructions.
- Only use with a Meridian 808/808i Signature Reference CD Player.
- Refer all servicing to approved service personnel.
- Connection to the mains should be carried out by a skilled and suitable qualified person.

Safety warnings

WARNING: TO REDUCE THE RISK OF FIRE OR ELECTRIC SHOCK, DO NOT EXPOSE THIS APPARATUS TO RAIN OR MOISTURE

- Do not expose the unit to dripping or splashing.
- Do not place any object filled with liquid, such as a vase, on the unit.
- Do not place naked flame sources, such as lighted candles, on the unit.

To avoid overheating

- Leave at least 10cm around the equipment to ensure sufficient ventilation.

Do not position the unit:

- In direct sunlight.
- Near heat sources, such as a radiator.
- Directly on top of heat producing equipment, such as a power amplifier.

To avoid interference

Do not position the unit:

- Near strong electrical or magnetic radiation, such as near a power amplifier.

Radio interference

FCC Warning: This equipment generates and can radiate radio frequency energy and if not installed and used correctly in accordance with our instructions may cause interference to radio communications or radio and television reception. It has been type-tested and complies with the limits set out in Subpart J, Part 15 of FCC rules for a Class B computing device. These limits are intended to provide reasonable protection against such interference in home installations.

EEC: This product has been designed and type-tested to comply with the limits set out in EN55013 and EN55020.



.....

Contents

.....

Introduction	1
The 808 Signature Reference CD Player	2
Specification	4
Using the 808 Signature Reference CD Player	5
Front panel keys	6
MSR+ keys	7
Switching on and off	8
Playing a disc	9
Stopping and pausing play	10
Repeat	11
Scanning a disc	12
Programming a selection	13
Changing the absolute phase	15
Changing the front-panel display	16
Using the CD player preamplifier features	17
Selecting a source	18
Adjusting the system volume	19
Changing the balance	20
Installing the CD player	21
Unpacking	22
Applications	24
Configuring the CD player	29
Choosing a standard setting	30
Setting up sources	32
Glossary	35
Index	37

Copyright and acknowledgements

Sales and service in the UK

Meridian Audio Ltd
Latham Road
Huntingdon
Cambridgeshire
PE29 6YE
England

Tel (01480) 445678
Fax (01480) 445686

Sales and service in the USA

Meridian America Inc
8055 Troon Circle
Suite C
Austell
GA30168-7849
USA

Tel (404) 344 7111
Fax (404) 346 7111

World Wide Web – <http://www.meridian-audio.com>

Designed and manufactured in the UK by

Meridian Audio Ltd
Latham Road
Huntingdon
Cambridgeshire
PE29 6YE
England

Copyright © 1999-2004 Meridian Audio Ltd.
Part no: 808U/1

MP3 is a registered trademark of
Thompson Multimedia.
BoothroydStuart Meridian, and
Meridian are registered trademarks
of Meridian Audio Ltd.

This guide was produced by:
Human-Computer Interface Ltd,
<http://www.interface.co.uk>



Introduction

Welcome to the Meridian 808 Signature Reference CD Player!
This User Guide provides full information about using the CD player in conjunction with your other equipment, to achieve the superb results you can expect from it.



The 808 Signature Reference CD Player

The 808 Signature Reference CD Player takes Compact Disc playback to an entirely new level, with a heritage that includes the multiple award winning 508 and 800, and two dozen optical disc players from 1984 to the present day. The 808 is specifically designed as a CD-optimised machine, able to play virtually any CD, from conventional pressings to CD-R, CD-RW, and discs of MP3 files (64–256kbps). It also plays the CD layer of an SACD disc.

At the heart of the 808 are fully-integrated electronics and a computer-style CD/DVD-ROM drive. The drive normally operates at standard CD speed, but is capable of much faster reading, using multiple high-speed re-reads to ensure accurate recovery of data from even the most difficult disc. This capability alone provides over ten times the error correction of a conventional CD player.

Digital Signal Processing

Once the digital data stream has been recovered from the disc, powerful on-board digital signal processing (DSP) with a capability of an impressive 150 MIPS (million instructions per second) up-samples the digital information from the 16-bit, 44.1kHz signal of conventional CD to a 24-bit signal with a sample rate of 176.4kHz. This signal is fed to the latest DVD-Audio quality delta-sigma digital to analogue converters to drive the analogue outputs, while a digital signal at an 88.2kHz sample rate is supplied to the digital outputs. Upsampling in this way enables filtering to take place far beyond the range of human hearing, as well as offering other audible benefits, right across the audio band, for ultimate transparency from a CD source.

The 808 employs a triple buffering system to minimise jitter, and therefore maximise HF transparency and stereo image precision and stability. This, and the digital electronics as a whole, are driven by a new design of high-stability clocking system which further reduces jitter and ensures that the highest level of detail is recovered from a disc. All digital data is accurately re-clocked.

Multiple power supplies ensure that digital and analogue circuitry are kept apart and can provide the required power when called upon to do so.

Integrated preamplifier

The 808i version of the 808 Signature Reference CD Player includes a built-in stereo preamplifier with the ability to handle six stereo analogue inputs, three digital coaxial S/PDIF inputs, and two Toslink optical digital inputs, making it ideal as the heart of a superb stereo system.

System integration

The 808 Signature Reference CD Player provides balanced and unbalanced analogue outputs for connecting to an external power amplifier or preamplifier. Alternatively, it provides coax digital outputs, allowing it to drive Meridian DSP Loudspeakers directly. The digital outputs support MHR (Meridian High Resolution) and operate at up to 2 x CD sample rate (88.2kHz), 24-bit. An auxiliary digital output can be used to connect to a surround decoder, or feed a second zone.

Meridian Comms sockets (2 x DIN) allow communication with other Meridian components, while an RS232 interface provides full remote control capability as well as the ability to configure the unit with Meridian's innovative Windows-based graphic configuration application. Three programmable trigger outputs are provided for direct control of external devices, for example powering-up amplifiers, etc.

The Meridian 808 Signature Reference CD Player is supplied with the MSR+ learning/programmable remote control, which not only operates all Meridian products but also includes an extensive database of third-party products and the capability to learn commands from existing remotes.

MP3 audio CDs

In addition to playing CD Audio (CD-DA), CD-R, CD-R/W, and DTS-CD format discs, the 808 Signature Reference CD Player can play CD-ROMs containing directories of MP3 audio files. This provides a convenient way of archiving record collections to achieve up to 10 times the capacity of a conventional CD where sound quality is not of primary importance.

MP3 discs can be created from a computer using appropriate MP3 encoding software and a CD-ROM writer. Generate the MP3 files with a data rate of at least 128Kbits per second. Group the tracks into folders to create separate albums on the disc. Do not create folders within folders.

Tracks and albums are played in the order in which they are recorded onto the CD-ROM. Usually this will be in alphabetical order of filename.

Specification

Drive

- Internal CD/DVD-ROM drive.

Audio in and out

The 808 is supplied as standard with:

- 2-channel balanced audio output.
- 2-channel unbalanced audio output.
- 2-channel digital coax output with optional MHR encryption at high rate.

The 808i version also includes:

- 6 2-channel unbalanced analogue inputs. Adjustable sensitivity. Renameable legends.
- 3 2-channel digital coax inputs. Renameable legends. 32 to 96kHz sampling and up to 24-bit precision.
- 2 2-channel digital optical inputs. Renameable legends. 32 to 96kHz sampling and up to 24-bit precision.

Signal processing

The 808 uses Meridian's proprietary DSP software to provide the following powerful features:

- Upsampling.
- FIFO and error correction.
- Resolution enhancement.

Controls, etc.

Front-panel facia controls for:

- Open/Close, Play, Stop, Pause, Previous, Next, and On/Off.

A hinged control panel provides additional controls for:

- Repeat, Fast Forward/Reverse, Source, Store, Clear, Display, Mute, and Volume +/-.

Display

- 20-character dot-matrix display with adjustable brightness and contrast.
- Indicators for Emphasis, Repeat, and Phase.



Using the 808 Signature Reference CD Player

This chapter provides a summary of the functions of the 808 Signature Reference CD Player to identify the controls which you use to operate the unit.

It also provides step-by-step instructions for operating the CD player, using either the front panel or the MSR+.



Front panel keys

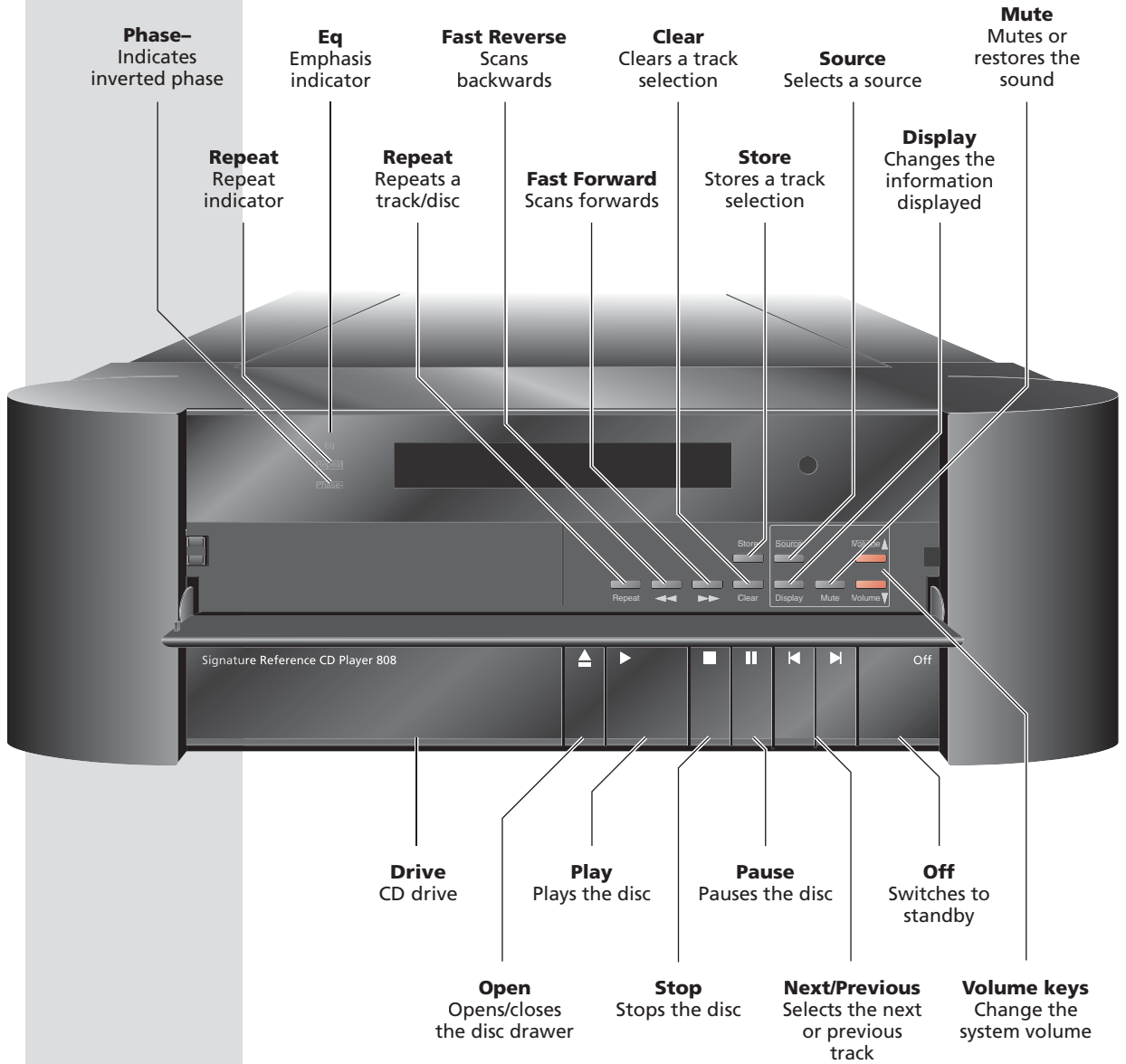

MSR+ keys

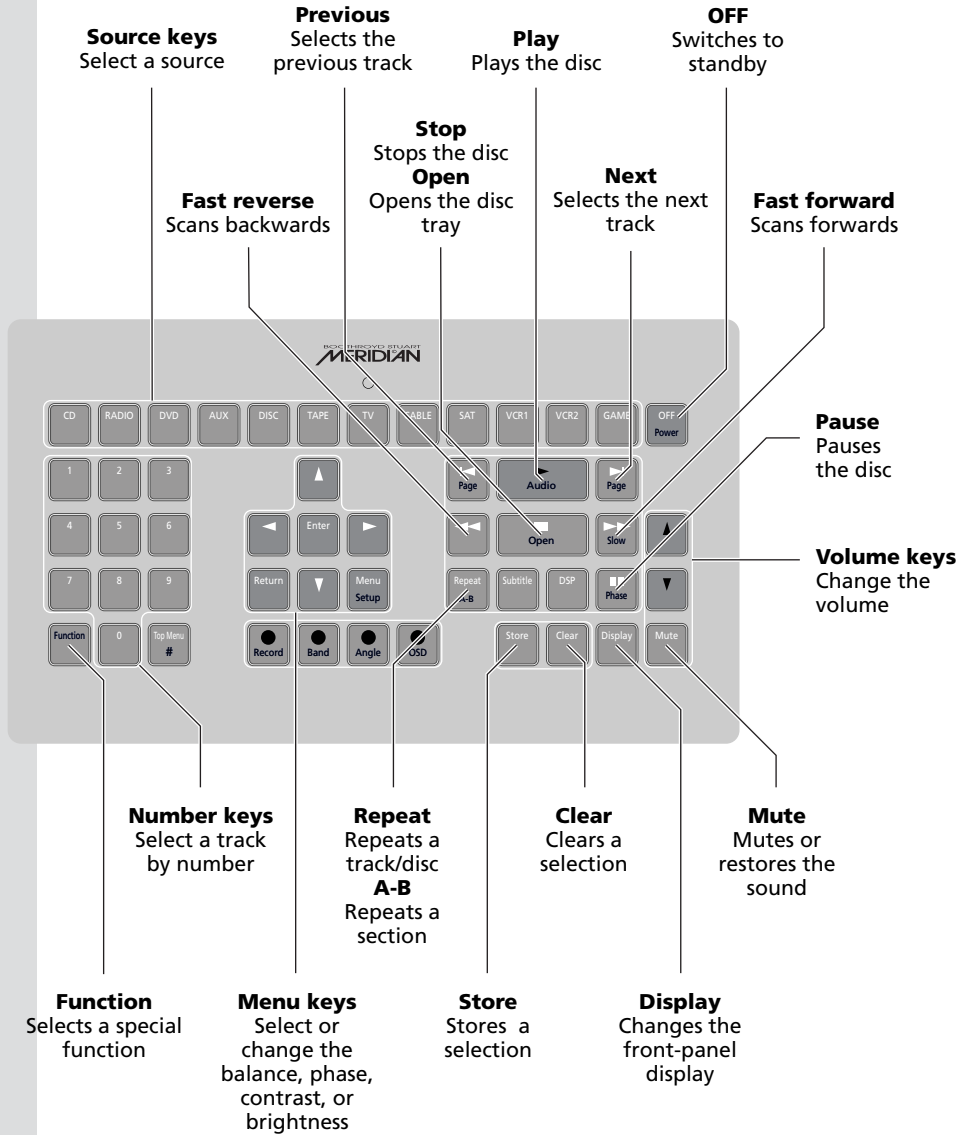

Switching on and off

When not playing, the CD player should be left in the standby state. This uses a minimal amount of electricity, but ensures that the components of the CD player operate at maximum efficiency from the moment you start.

If you are not going to use the CD player for several days you should switch the unit off completely at the rear panel, and disconnect it from the AC power supply.

To switch on from standby

- Press ▲, ■, or ► (front panel), or select a source on the remote.

If the CD player is part of a Meridian system it will automatically switch on any other units in the system, such as the 861 Reference Digital Surround Controller and Meridian DSP Loudspeakers.

To insert a disc

- Press ▲ (front panel) or **Open** (remote) to open the tray.
- Place your disc in the tray, label side up.
- Press ▲ (front panel), **Open** (remote), or ► to close the tray.

To switch to standby

- Press **Off**.

If you have other Meridian equipment or Meridian DSP Loudspeakers connected to the CD player these units will also switch to standby.

If a disc is currently playing, switching to standby will stop the disc, and the disc can safely be left in the unit.

Always remove any disc before moving or shipping the 808.

Playing a disc

The compact disc player allows you to play an entire disc, or start playing from any track. While a disc is playing you can go back to the start of the track or skip to the start of the next track.

If you have programmed a selection, these functions also work with the selection of tracks you have programmed. For information about programming see *Programming a selection*, page 13.

To play the disc

- Press ► (front panel or remote).

The display will show your selection:



Play 1

The display will then show the track number and elapsed time:



1 00:12

To restart the current track

- Press ◀ (front panel or remote).

To move to the next track

- Press ► (front panel or remote).

To play starting from a particular track

- Press ► or ◀ (front panel or remote) to step through the track numbers until the track you want to play is displayed, or type the number of the track (remote only).

For example:



Track 4

After a short delay the track you have selected will start to play.

If you have other Meridian sources you should ensure that the 808 is the currently selected source.

Stopping and pausing play

You can pause a disc while keeping it spinning, so that you can resume play instantly.

To stop playback

- Press ■.

The display will show the total number of tracks on the disc and the total time.

For example:



16 68:57

To pause playback

- Press II.

You can change tracks while the disc is paused using ◀ or ▶.

To continue after pausing

- Press II or ▶.

Repeat

You can choose to play a track, disc, or selection repeatedly, so that when it has played it will start again from the beginning; with MP3 discs you can also repeat the current album.

To continuously repeat a disc

- Press **Repeat** (remote or under the front panel) to select between the following options:

Display	Description
Repeat track	Repeat current track.
Repeat disc	Repeat entire disc.
Repeat album	Repeat album (MP3 discs only).

To repeat between two positions

- Press **A-B (Function Repeat)** on the remote) at the start of the section you want to repeat.

The display shows:

- Move to the end of the section you want to repeat.
- Press **A-B (Function Repeat)** on the remote) again.

The display shows:

The section you have specified will be played repeatedly.

To cancel A-B repeat

- Press **A-B**.

To cancel the repeat function

- Press **Repeat** (remote or under the front panel) again.



Scanning a disc

The scan controls allow you to move quickly to any position on the disc at approximately 20 times normal speed.

During scanning you hear samples of the sound, and the display automatically changes to show the elapsed time for the whole disc unless you have already selected one of the other time displays.

This function is only available from the remote.

To scan through a disc

- Press ►► or ◀◀.

The display will show you the position on the disc; for example:



3 12:37

- Press ► when you have reached the position you want to play.



Programming a selection

You can programme a selection of tracks and then play only the tracks you have programmed.

You can programme a selection either by storing the tracks you want to play, or by clearing the tracks you do not want to play. If you programme a selection by storing the tracks you want to hear, you can play the tracks in any order and repeat tracks in the sequence.

You can programme a selection while the disc is playing, in which case the selection will be played after the current track finishes.

To choose a track to programme

- Press **◀** or **▶** to step through the track numbers until the track you want is displayed, or type the number of the track you want.

To make a selection by adding tracks

- Choose the first track you want to play, as described above.

The display will show the track number; for example:



Track 14

- Press **Store**.

The track will change from **Track** to **Store**, and all the other tracks will be marked **Clear**.

For example:



Store 14

You should store the first track for a selection within two seconds, or it will begin to play.

To make a selection by omitting tracks

- Choose one of the tracks you do not want to play, as described above.

The display will show the track number; for example:



Track 12

- Press **Clear**.

The track will change from **Track** to **Clear**, and all the other tracks will be marked **Store**.

For example:



Clear 12



You should clear the first track for a selection within two seconds, or it will begin to play.

To add or remove a track from a selection

- Select the track using ◀ or ▶.

Alternatively you can enter the track number using the remote.

- Press **Store** to add the track, or **Clear** to remove the track.

To clear a programme

- Press ■ twice.

The display will show:



Clear Program

A programme is automatically cleared if you open the disc drawer, or press **Off**.



Changing the absolute phase

You can use the remote to invert the absolute phase of the analogue output signal, which in some circumstances can give a noticeable improvement in realism.

To display the phase setting

- Press **Phase (Function Pause)** on the remote).

The display will show:



To change the phase setting

- Press **Phase (Function Pause)** on the remote) again.

The display will show the new phase setting; for example:



Changing the front-panel display

The 808 Signature Reference CD Player displays information about the current disc and settings on the 20-character front-panel display.

You can adjust the contrast and brightness of the front-panel display for optimum viewing, and choose what information is displayed.

To change the contrast or brightness

- Press **▶** or **◀** (remote), until the display shows the current contrast or brightness.

For example:

A black rectangular display showing the text "CD Contrast 10" in a white, monospaced font.



- Press **▲** or **▼** (remote), to change the selected setting.

You can change the contrast or brightness between 0 and 15.

To change the displayed information

- Press **Display** (remote or under the front panel).

Each time you press **Display** the display will step between the following options:

Display option	Example
Track and elapsed time	
Sampling rate, precision, and audio format	
Blank	

If the **Diagnostic displays** option has been selected, additional diagnostic displays are included; see the *Meridian Configuration Program Guide*.



Using the CD player preamplifier features

The 808i version of the 808 Signature Reference CD Player includes a preamplifier, and can act as the controller for up to 11 other sources.

Both models feature an optional volume control for the analogue inputs.

This chapter explains how to use these features from either the front panel or the MSR+.



Selecting a source

If you are using the 808i Signature Reference CD Player as a controller you can connect up to 11 other sources to it, and select them from the front panel or remote.

The CD player provides the following 12 sources:

CD, Radio, DVD, Aux, Disc, Tape, TV, Cable, Sat, VCR1, VCR2, and Game.

Your installer may have customised the labels displayed for each source to suit your other equipment

The CD source usually corresponds to the internal drive.

The input associated with each of the other sources depends on how the CD player has been set up; for more information refer to the *Meridian Configuration Program Guide*.

To select a source

- Press **Source** (under the front panel) until the display shows the source you want, or press the appropriate source key on the remote; eg **CD**.

The display shows the source and volume setting.

For example, if you select the Radio source the display might show:

A rectangular digital display with a black background. The word 'Radio' is shown on the left in a white, pixelated font, and the number '65' is shown on the right in the same font.

The 808 CD player mutes the sound while you change source.

Adjusting the system volume

The 808 Signature Reference CD Player provides an optional volume control on the analogue outputs, enabling it to drive amplifiers or active loudspeakers directly, and you can adjust the volume using the front panel or remote.

The volume changes in precise steps of 1dB, where 9dB is equivalent to doubling the loudness. The current volume setting is displayed in dB on the front-panel display, and can be varied in the range 1 to 99dB.

To change the volume

- Press **Volume ▲** or **Volume ▼** (under the front panel), or the red **▲** or **▼** keys on the remote.

As you adjust the volume setting the display shows the current volume level.

For example:



To mute the sound

- Press **Mute** (under the front panel, or remote).

The display will show:



To restore the sound

- Press **Mute** again.

Alternatively, the sound will be restored if you adjust the volume.

Changing the balance

To change the balance

- Press ◀ or ▶ (remote or under the front panel) until the display shows the current balance.

For example:

A black rectangular display area with white text. The text reads "CD Balance <0>".

- Press ▲ or ▼ (remote or under the front panel) to move the listening position.

The display shows the direction and position of the listening position.

For example:

A black rectangular display area with white text. The text reads "CD Balance <3>".

The arrow indicates the direction, and the number indicates the position where 0 is central, 8 is in line with the corresponding main speaker, and 10 is fully to one side.

Installing the CD player

This chapter explains how to install the 808 or 808i CD player. It describes what you should find when you unpack the product, and how you should connect it to the other equipment in the system. You should not make any connections to the product or to any other component in the system while the AC power supply is connected and switched on.



Unpacking

The 808 Signature Reference CD Player is supplied with the following accessories:

- MSR+ remote control with batteries, manual, and spare key caps.
- Meridian Comms lead.
- Power cord.
- This manual.

If any of these items are missing please contact your dealer.

NOTE: You should retain the packaging in case you need to transport the unit.

Back panel

The following diagram gives details of the back panel connections:

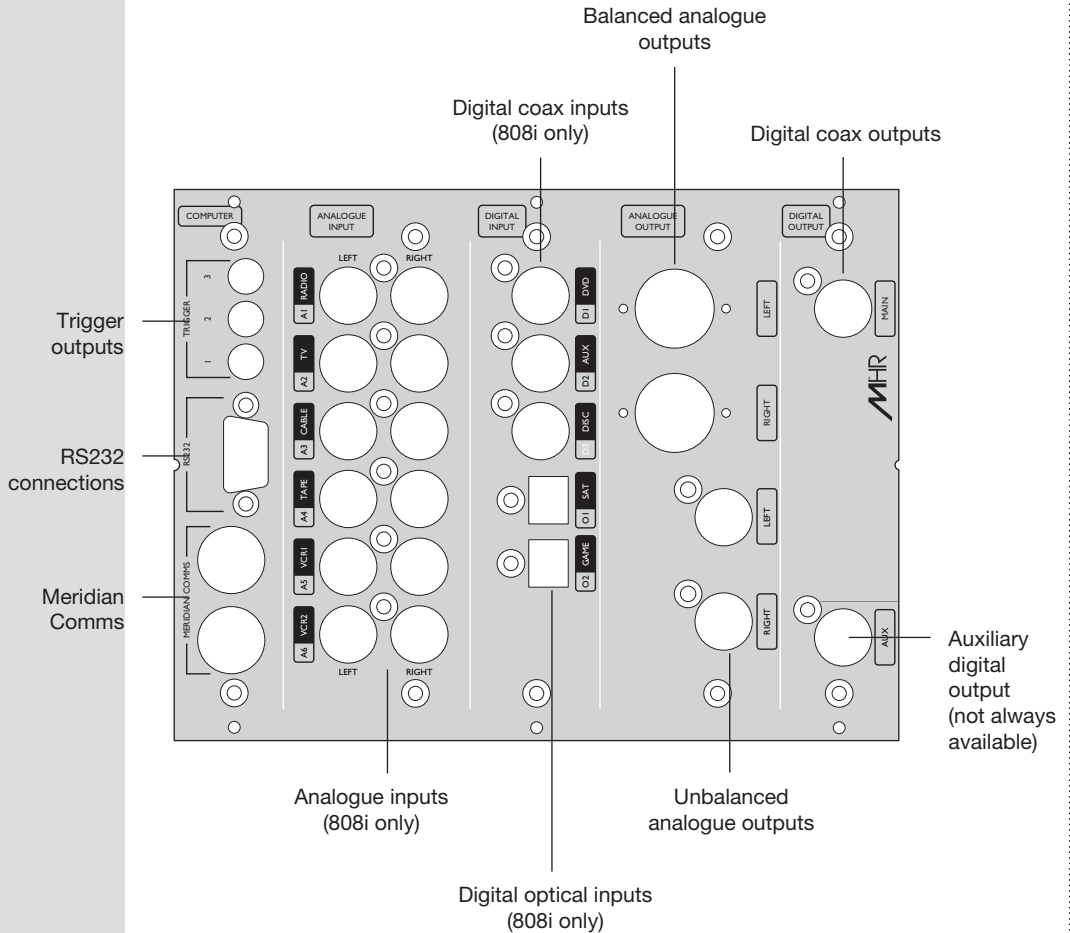

Audio outputs

Use this output	To connect to this
BALANCED OUT	The balanced analogue inputs of a preamplifier, or a power amplifier such as the G57, using XLR leads.
ANALOGUE OUT	The unbalanced analogue inputs of a preamplifier, or a power amplifier such as the G57, using analogue phono leads.
DIGITAL OUT	The digital input of a surround processor, such as the 861 Reference Digital Surround Controller, or DSP loudspeakers, using a 75Ω digital cable.
AUX DIGITAL OUT	The digital input of an additional surround processor or a pair of DSP loudspeakers, when the main output is being used. For highest sound quality the AUX output is not always available; see <i>To enable or disable the AUX output</i> below.

Audio inputs (808i only)

Use this output	To connect to this
ANALOGUE IN A1 (Radio), A2 (TV), A3 (Cable), A4 (Tape), A5 (VCR1), A6 (VCR2)	The analogue outputs of a source, such as a TV or tape deck.
DIGITAL INPUT D1 (DVD), D2 (Aux), D3 (Disc)	The digital output of a source such as a DVD player.
OPTICAL INPUT O1 (Sat), O2 (Game)	The optical output of a source such as a satellite receiver.

The default assignment of the source to each input is shown in brackets after the input name in the above table. CD corresponds to the internal CD player.

Communications connections

Use this connection	To connect to this
MERIDIAN COMMS	Other Meridian G Series, 500 Series, or 800 Series equipment, or Meridian DSP loudspeakers.
RS232 connection	A computer, for configuring the CD player.
TRIGGER OUTPUT 1, 2, 3	Equipment that can be triggered by a 12V 100mA signal.

To enable or disable the AUX output

- Switch the CD player to standby.
- Hold down **Repeat** (under the front panel).

The display switches between:

AUX always available

and:

192k direct to DAC

Applications

To connect to an analogue preamplifier (Type 1 or 2)

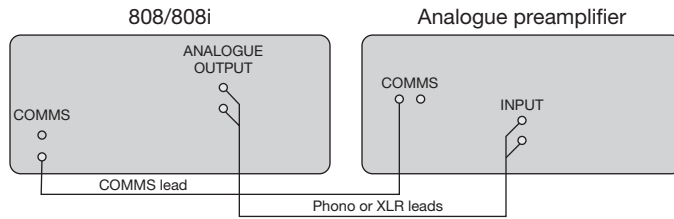

- Connect the balanced or unbalanced analogue outputs to the appropriate inputs on the preamplifier.
- If the preamplifier is a Meridian product, such as a G02, connect together the COMMS sockets using the Comms lead provided.
- Configure to Type 1 if using an 808 or 808i with no external inputs, or Type 2 for an 808i with other inputs in use; see *Choosing a standard setting*, page 30.

To connect to an 861 Reference Digital Surround Controller (Type 1 or 2)

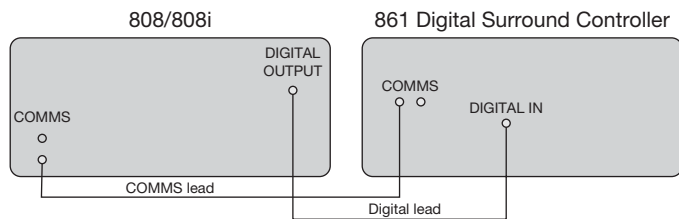

- Connect the DIGITAL output from the 808/808i to a suitable Digital input on the digital surround controller, using a digital lead.
- Connect together the COMMS sockets using the Comms lead provided.
- Configure to Type 1 if using an 808 or 808i with no external inputs, or Type 2 for an 808i with other inputs in use; see *Choosing a standard setting*, page 30.

To connect to two-channel DSP loudspeakers (Type 1 or 2)

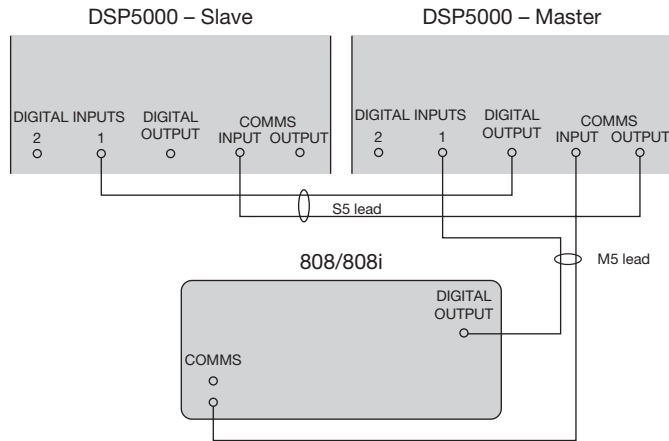

The 808/808i can be connected directly to Meridian DSP loudspeakers to create a complete compact stereo system, with volume and other preamplifier controls provided by the loudspeakers via the MSR+ or the front panel. The 808i provides additional analogue and digital inputs allowing you to use it to control the other sources in your system.

- Connect the DIGITAL OUTPUT and a COMMS socket from the CD player to DIGITAL INPUT 1 and the COMMS input on the DSP loudspeaker chosen as the master, using an M5 lead.
- Connect the DIGITAL and COMMS outputs from the master DSP loudspeaker to DIGITAL INPUT 1 and the COMMS input on the other (slave) DSP loudspeaker, using an S5 lead.
- Configure the loudspeakers as described in the *Meridian DSP Loudspeaker User Guide*.
- Configure to Type 1 if using an 808 or 808i with no external inputs, or Type 2 for an 808i with other inputs in use; see *Choosing a standard setting*, page 30.

To connect the 808/808i to a power amplifier (Type 0 or 3)

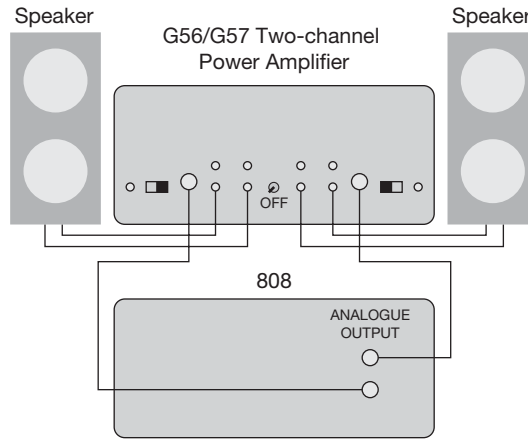

The 808 includes an integrated preamplifier, allowing you to connect it directly to a pair of analogue active loudspeakers, or to analogue passive loudspeakers via a power amplifier such as the G56 or G57.

- Connect the ANALOGUE OUTPUT connections from the CD player to the inputs of the analogue active loudspeakers or power amplifier, using phono leads.
- If you are using an 808i connect your other sources to the appropriate inputs.
- Configure to Type 0 if using an 808 or 808i with no external inputs, or Type 3 for an 808i with other inputs in use; see *Choosing a standard setting*, page 30.

To connect to other Meridian G Series, 500 Series, or 800 Series equipment

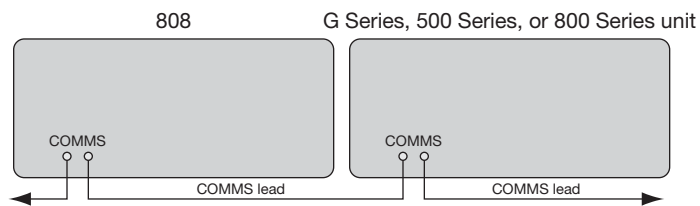

In a system of Meridian products, one of the products acts as the controller for the system, receiving infra-red commands from the MSR+ and then, if appropriate, relaying them to the other products via the Comms link.



The following automatic setup procedure should be used to set up the Comms correctly between several products:

- Connect one of the DIN COMMS sockets on the back panel of the CD player to one of the COMMS sockets on another G Series, 500 Series, or 800 Series unit, using the Comms leads provided with the products.

The sequence in which you connect the units is not important.

- Switch all the units to standby.
- Press **Clear** (remote).

Each unit will display:



One unit will then be designated as the controller, and display:



All the other units will be configured as non-controllers, and display:



If for any reason the automatic setup does not work, make sure you are operating the remote from a position where all the units can receive the infra-red, and try again.

If this fails:

- Restore the default operation by selecting one of the standard types; see *Choosing a standard setting*, page 30.

Do not, under any circumstances, connect any equipment other than Meridian G Series, 500 Series, or 800 Series to any socket marked COMMS on the back of the product.



.....

.....

Configuring the CD player

This chapter explains how to set up the 808 Signature Reference CD Player for most standard configurations of your other equipment, using just the front-panel controls and MSR+.

For complete control over all aspects of the CD player's configuration it is recommended that you set up the unit using the Meridian Configuration Program; for full information see the *Meridian Configuration Program Guide* available separately.



Choosing a standard setting

The CD player provides several sets of standard settings, called Types, which configure all aspects of the 808 into one of a number of alternative standard configurations.

Types 0 to 3 are factory settings, designed to cater for the most commonly needed configurations of associated equipment.

These standard Types are shown in the following table:

Type	Description
0	CD player, variable output, all sources internal.
1	CD Player, fixed output, all sources internal.
2	Preamplifier, fixed output, CD internal, all other sources external (808i only).
3	Preamplifier as above but variable output (808i only).

In addition, your installer may have provided one or more named User Types, with settings appropriate to the configuration of equipment when your 808 was installed.

You can reset the configuration of the CD player to any of these Types to restore it to the state it was in when it was installed. **Note:** Selecting a Type will clear any configuration changes you have made.

To select a standard setting

Warning: this procedure will reset any configuration changes you have made.

- Switch off any power amplifiers that are connected to the 808 and put any digital speakers into standby.
- Put the CD player into standby by pressing **Off** (front panel or remote).
- Press and hold down **Volume ▲** (under the front panel).

The display shows:

Type in... 3

- Keep holding down **Volume ▲** for a further three seconds.

The display shows:

Type- please wait

Then after a short delay the display shows the current Type.

For example:

Type 1

- Press ▲ or ▼ on the front panel to change the Type number.

The display shows:

Typing, please wait.

- Wait for one second, and then put the CD player into standby by pressing **Off** (front panel or remote).
- Switch on again to use the standard settings you have selected.

Setting up sources

This section explains how to use Gain mode to set up the analogue sources connected to the CD player.

To turn on Gain mode

- Put the CD player into standby by pressing **Off** (front panel or remote).
- Press and hold the **Volume ▼** key under the front panel for at least five seconds.

The display shows:

Gain On

The CD player will then return to standby with Gain mode turned on.

Gain mode adds an extra **Sensitivity** option to the menus.

To turn off Gain mode

- Repeat the above procedure until the display shows:

Gain Off

To adjust the sensitivity of a source

To obtain the best signal-to-noise ratio for your analogue sources you can adjust the sensitivity of each input to give the highest level that does not produce clipping.

- Turn on Gain mode, as described above.
- Select the source you want to adjust, with loud source material playing.
- Press ◀ or ▶ (remote) until the display shows the current sensitivity.

For example:

Radio 2.0V In

- Press ▲ or ▼ (remote) to change the sensitivity.

You can select between sensitivities of 0.5V (most sensitive), 1.0V, 2.0V, or 2.5V (least sensitive).

If the sensitivity is set too high the input will clip the loudest passages.

The display shows, for example:

Radio 0.5V In Clip

In this case reduce the sensitivity.



If you have selected a digital source you cannot adjust the sensitivity.

The display shows, for example:



.....

.....

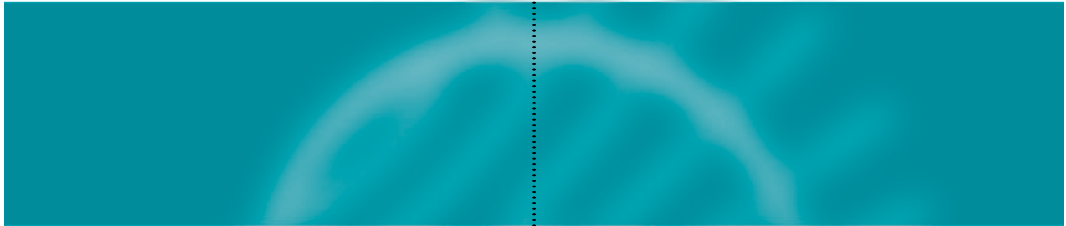

Glossary



Controller

The product in a Meridian system that uses the infra-red signals from the remote to control the system. The controller is normally chosen automatically, but the installer can override this.

Menus

The flexible system for choosing options and configuring settings in Meridian products. On the 808 the menus are controlled by the ◀, ▶, ▲, and ▼ keys on the remote.

MHR

Meridian High Resolution is a proprietary secure encoding format using encryption and anti-copy methods that allows secure transfer of audio streams between elements of a Meridian-only system for the purpose of playback only. It provides a secure copyright protection environment and has the very important benefit of lowering jitter and improving sound quality on all material.

MSR+

The Meridian System Remote, or handset.

PCM

Pulse Code Modulation, the method used to encode music digitally, as used on audios CDs.

Source

An input to the system, such as CD or TV. The Meridian 800 and G Series products provide 12 named sources, corresponding to the names of the 12 source keys on the MSR+. In the 808 you can choose the label displayed for each source, and the input used for it.

Type

A standard configuration of the CD player. Selecting a Type resets any configuration changes.

Index

A

absolute phase 15
accessories 22
automatic setup 26
auxiliary output 22
enabling or disabling 23

B

back panel connections 22
balance, changing 20
balanced outputs 22,23
brightness, front-panel display 16

C

clip indicator 32
Comms, connecting 23,26
communications connections 23
configuring 29
connecting
to an 861 Reference Digital Surround Controller 24
to a power amplifier 26
to DSP loudspeakers 25
to Meridian G Series, 500 Series, or 800 Series equipment 26
continuing play 10
contrast, front-panel display 16

D

display, front panel 16
DSP loudspeakers, connecting 25

F

front panel keys 6

G

Gain mode 32
glossary 35

I

inputs 23

M

Meridian Digital Surround Controller, connecting to 24
Meridian DSP loudspeakers, connecting to 25
Meridian System Remote keys 7
MP3 discs
creating 3
muting the sound 19

O

outputs 23

P

pausing play 10
continuing after pausing 10
phase
changing 15
reviewing 15
playing a disc 9
from a particular track 9
repeatedly 11
preamplifier features 17
programming a selection 13
clearing 14

R

repeating play 11
cancelling 11
restarting the current track 9
RS232 connection 23

S

scanning a disc 12
selections
adding a track 14
clearing 14
programming 13
specifying tracks not to play 13
sound, muting 19

sources 18

adjusting sensitivity 32

selecting 18

specification 4

standard settings, selecting 30

standby, switching to 8

stopping play 10

switching on and off 8

T

tracks

playing from a particular track 9

restarting the current track 9

trigger outputs 23

Types 30

U

unpacking 22

V

volume, adjusting 19