

# Meridian C Series Installation Components C52 Dual Active Subwoofer Controller

## Installation and Operation Manual



**IMPORTANT: PLEASE READ THIS COMPLETE MANUAL TO ENSURE PROPER INSTALLATION AND OPERATION.**

**INSTALLERS:**

Please review this manual carefully before contacting Technical Support.

**PRODUCT OWNERS:**

Please contact your authorised Meridian dealer for product or installation questions.

BOOTHROYD STUART  
**MERIDIAN**<sup>®</sup>

*This page intentionally left blank*

## CONTENTS

IMPORTANT SAFETY INSTRUCTIONS .....	4
SERVICE AND GUARANTEE .....	5
ABOUT THE PRODUCT .....	6
C52 SPECIFICATIONS .....	6
INSTALLATION AND SETUP.....	7
CONNECTING THE C52.....	8
CONFIGURING THE C52.....	10
TROUBLESHOOTING .....	11

Please review the instructions in the following pages of this manual to help insure a smooth installation and a happy customer.

## **IMPORTANT SAFETY INSTRUCTIONS**

- Read the instructions.
- Keep these instructions.
- Follow all instructions.
- Do not use this apparatus near water.
- Clean only with a dry cloth.
- Install only in accordance with manufacturer's instructions.
- Refer all servicing to approved service personnel.

This apparatus has been designed with Class 1 construction and must be connected to a mains socket outlet with a protective earth connection (the third grounding prong).

Do not defeat the safety purpose of the polarized or grounding-type plug. A polarized plug has one prong wider than the other. A grounding type plug has two blades and a third grounding prong. The wide blade or the third prong are provided for your safety. If the provided plug does not fit into your outlet, consult an electrician for replacement of the obsolete outlet.

**WARNING: TO REDUCE THE RISK OF FIRE OR ELECTRIC SHOCK, DO NOT EXPOSE THIS APPARATUS TO RAIN OR MOISTURE**

This apparatus uses a single-pole power switch. As a result it is not isolated from AC mains power when switched off at the rear panel. The apparatus may be isolated from mains power either by unplugging the power connector from the rear of the unit, or by unplugging the connector at the opposing end of the power cord or cable from its supply outlet. As a result, either or both of these connectors should remain accessible.

### **Safety warnings**

- Do not expose the unit to dripping or splashing.
- Do not place any object filled with liquid, such as a vase, on the unit.
- Do not place naked flame sources, such as lighted candles, on the unit.

### **To avoid interference**

Do not position the unit:

- Near strong magnetic radiation.
- Near to a television, or where connecting cables may be subject to or cause interference.

### **To avoid overheating**

- Leave at least 10cm around the equipment to ensure sufficient ventilation.

### **Do not position the product:**

- In direct sunlight.
- Near heat sources, such as a radiator.
- Stacked with any other audio products other than in a properly ventilated rack, as the heat it generates may damage the other products.

The sides and top of the C52 case contain venting holes for the internal heatsinks which should not be obstructed. Ensure that air can flow around them. The product normally runs warm to the touch when not in standby.

Warning: The C52 is moderately heavy; take care when lifting it.

### **Radio interference**

FCC Warning: This equipment generates and can radiate radio frequency energy and if not installed and used correctly in accordance with our instructions may cause interference to radio communications or radio and television reception. It has been type-tested and complies with the limits set out in Subpart J, Part 15 of FCC rules for a Class B computing device. These limits are intended to provide reasonable protection against such interference in home installations.



EU: This product has been designed and type-tested to comply with the limits set out in EN55013 and EN55020.

## Warning: live terminals



Terminals marked with the 'lightning flash' symbol are hazardous live and the external wiring connected to these terminals requires installation by an instructed person or the use of ready-made leads or cords.

## Information for Users on Disposal of Old Equipment (EU Only)

### Attention:

This symbol is only valid in the European Union.



### [European Union]

This symbol indicates that the electrical and electronic equipment should not be disposed of as general household waste at its end-of-life. Instead, the product should be handed over to the applicable collection point for the recycling of electrical and electronic equipment for proper treatment, recovery and recycling in accordance with your national legislation. By disposing of this product correctly, you will help to conserve natural resources and will help prevent potential negative effects on the environment and human health which could otherwise be caused by inappropriate waste handling of this product. For more information about collection point and recycling of this product, please contact your local authority, your household waste disposal service or the shop where you purchased the product. Penalties may be applicable for incorrect disposal of this waste, in accordance with national legislation.

(Business users)

If you wish to dispose of this product, contact your Meridian dealer or distributor or Meridian Audio Ltd to obtain information about the take-back of the product.

### [Other Countries outside the European Union]

If you wish to dispose of this product, please do so in accordance with applicable national legislation or other rules in your country for the treatment of old electrical and electronic equipment.

## Accessory Kit

The following items are supplied with C52 Dual Subwoofer Controller

1 - This manual

1 - Power Cord

Cables for connection to a Meridian Digital Theatre System.

## SERVICE AND GUARANTEE

### Service

The Meridian components have been carefully designed to give years of untroubled service. There are no user-serviceable parts inside the case, nor do the units require any form of maintenance.

In the unlikely event that your subwoofer fails to function correctly, it should be returned, in its original packaging, to your Meridian dealer.

In case of difficulty within the UK or USA please contact Meridian Audio Limited or Meridian America Inc respectively.

In case of difficulty outside the UK or USA, contact the importing agent for the territory. A list of Meridian agents abroad is available from Meridian.

No responsibility can be accepted for the subwoofer whilst in transit to the factory or an agent, and customers are therefore advised to insure the unit. When seeking service under guarantee, proof of the date of purchase will be required.

### Guarantee

Each unit is guaranteed against defects in material and workmanship for two years from the date of purchase.

The guarantee is void if the unit has been subject to misuse, accident, or negligence, or has been tampered with or modified in any way without the written authorisation of Meridian Audio Limited.

**Note:** Connecting anything other than the

correct network lead to the COMMS sockets may cause damage to the subwoofer which will not be covered by this guarantee.

Attempted servicing by unauthorised people may also invalidate this guarantee. Labour and carriage charges are not covered unless by local agreement.

Outside the UK, local warranty liability is restricted to equipment purchased within the territory. Our agents abroad are only under contractual obligation to service under guarantee equipment sold through them. They are entitled to make a non-refundable charge for any service carried out on other equipment. This guarantee does not limit your statutory rights within the United Kingdom.

## ABOUT THE PRODUCT

The Meridian C52 combines the finest materials with state of the art design to create what we believe is a superior subwoofer controller, emphasising extreme bass, depth, clarity, control, and articulation.

Each unit provides two controller and power amplifier channels allowing the use of two independent subwoofers. Both digital and active analogue inputs are provided, allowing the C52 to be connected either to a digital surround controller or digital source with a digital coax output, or to an analogue preamplifier or surround controller with either phono or balanced outputs.

### Digital connectivity

The unit employs 96kHz/24bit digital-to-analogue conversion and accept digital inputs up to 96kHz including those carrying MHR signals.

Separate analogue and digital power supplies are used to feed the C52's precision electronic circuits, ensuring that both high and low power sections receive continual smooth supply.

If you are using the subwoofers with a digital source, such as CD or DVD, the signals remain in digital form until the last possible stage.

### Subwoofer drivers

The C52 is designed to be used with Meridian Installation Series subwoofer driver assemblies such as the SW320. However, passive subwoofers with similar specifications and capabilities may alternatively be employed.

### Power amplifiers

The C52 includes Class D high efficiency ultra low output impedance amplifiers, optimised for both music and movie soundtracks.

The whole electronic assembly is supplied from substantial toroidal transformers feeding high-quality, audiophile-grade capacitors.

## C52 SPECIFICATIONS

Digital inputs	2 x cable inputs, 32–96kHz PCM using S/PDIF, or MHR connection support with auto-detection.
Analogue inputs	3 x phono inputs: mono, left, right, per channel. 2 x XLR balanced inputs: Channel 1 and Channel 2.
Output stage	Power amplifier: 300W Class D high efficiency ultra low output impedance (per channel).
Characteristics	Distortion <0.01%, typically <0.02% up to full power at all frequencies. Noise and hum < -72dBm. Frequency response 20Hz–400Hz.
Control	2 x sets Meridian Comms (BNC in and out; DIN in and out). Variable gain control (per channel). Variable low pass filter 40Hz–150Hz. Filter defeat switch (per channel). Absolute phase (polarity) switch (per channel).
Power	100/115/120V; 220/230/240V AC 50-60Hz. 20-500VA

Meridian Audio reserves the right to amend product specifications at any time.

## Accessories

Each unit is shipped complete with cables to enable it to be used in a Meridian Digital Music System.

Other applications, and some advanced features, may require one or more of the following accessories, which can be purchased from your Meridian dealer:

- Additional S5 leads (8m and 14m).
- 511 slave patch box if connecting more than two DSP loudspeakers to a Digital Surround Controller.

## INSTALLATION AND SETUP

### Unpacking

- Inspect product box and unit for any shipping damage.
- Save product box in the event the unit needs to be shipped in the future. Shipping the unit in a generic box may void warranty.

### Mounting

The C52 is primarily designed to be mounted in a standard 19in rack. However, screw-on optional feet are provided for free-standing operation. The feet should be removed if the unit is to be rack-mounted.

- EXCESSIVE HEAT MAY CAUSE THE UNIT TO MALFUNCTION OR SHORTEN PRODUCT LIFE. Follow regular installation rules for proper ventilation.
- Be sure rack location has adequate ventilation. Allow a minimum of 1U rack space (1.75in) above and below unit for ventilation.
- Allow additional ventilation when mounted near other power amplifiers or other equipment that may generate excessive heat.

### Connections

Be sure to use high quality cables for both sources and output signals.

### AC Power Connector

Connect to a stable AC power line. Ensure that the unit is connected to a supply of the voltage specified on the unit and that the unit is of the correct type for the territory in which it is being installed.

- To avoid ground loops, a power conditioner for the equipment rack is recommended.

- Static electricity can cause equipment problems. Be sure installer is grounded to chassis or equipment rack before connecting sources.

## CONNECTING THE C52

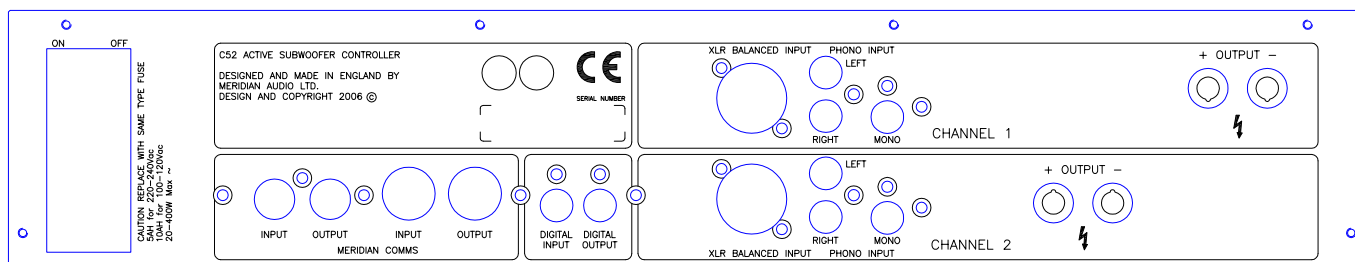

C52 Rear Panel (above) and front panel with acrylic cover removed (below)

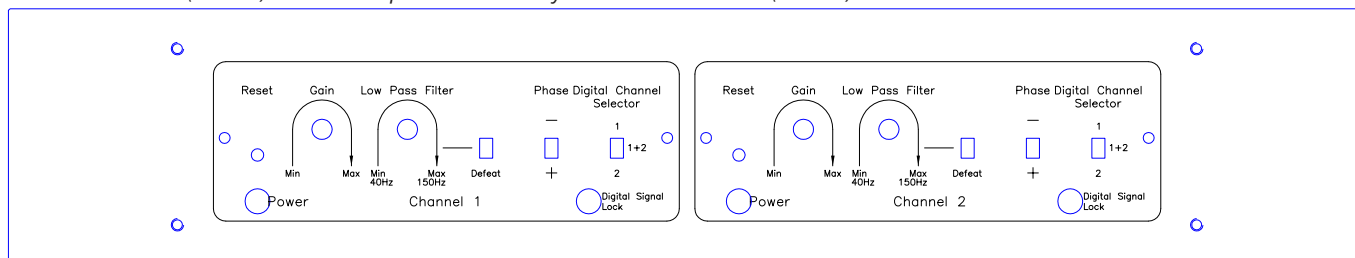

The C52 contains two identical subwoofer controllers, Channel 1 and Channel 2. Unless otherwise stated, this section refers to one section only.

### Output Connections

Connect the cables from the rear-panel output terminals to the loudspeakers. Be sure to observe correct polarity, and note that these terminals can develop significant voltages/current-passing capability when the C52 is powered up and being fed with an active signal. **Ensure that connections are made with the power disconnected from the unit.**

### Digital connections

Identify the S/PDIF digital connections on the rear panel as shown on the diagram above.

The Digital Input should be connected to a digital source, such as a digital sound processor, or digital preamplifier.

The Digital Output may be connected to a second (slave) DSP loudspeaker, using an S5 lead.

The S/PDIF cable connected to the digital input carries two channels. Set the DIGITAL CHANNEL SELECTOR switches on the front panel switch to indicate which channel(s) are directed to each subwoofer.

- If you are connecting the subwoofer to the Centre/Sub or Side/Sub output of a Meridian digital surround processor, set the switch to position 2.
- If your system includes a stereo pair of subwoofers, set the left subwoofer to position 1 and the right subwoofer to position 2.
- If you are connecting a single subwoofer to a stereo digital system with no centre channel output, such as a Meridian CD player, set the switch to position 1+2, to mix the signals from both channels.
- The digital connections should be made with high-quality 75Ω screened cable. Suitable cables are available from Meridian.
- We do not recommend using analogue audio cables, which do not have adequate shielding or the correct impedance, or cables intended for UHF applications, as these do not provide adequate shielding in the 1–30MHz region.
- When a digital signal is applied to a channel, the front panel “Digital Signal Lock” indicator will illuminate to show that the digital signal is being correctly received.

### Communications connections

Connect the Meridian Communications sockets to the COMMS connection on a Meridian control unit or preamplifier, using a COMMS lead.

## To connect a subwoofer in a Meridian digital surround system

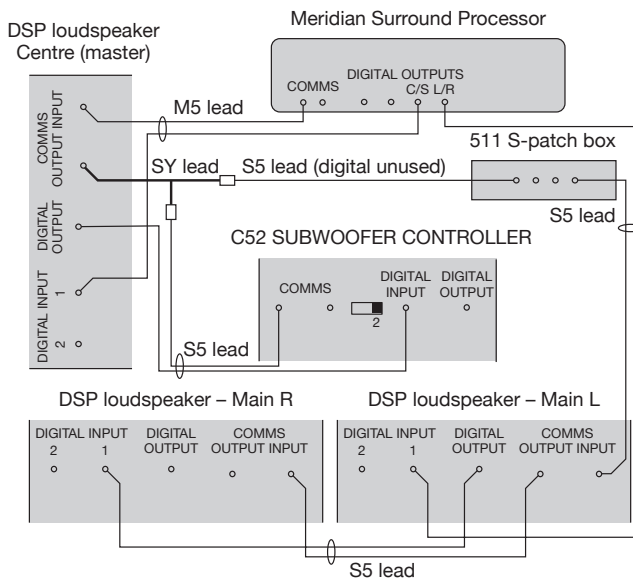

If your system includes more than two Meridian DSP loudspeakers you will need a 511 slave patch box (available separately) to link together the S5 leads from each speaker, as shown above.

- *Note: This may not apply to the 861, which may be ordered with a built-in patch box.*
- Use the comms part of an M5 lead to connect one of the COMMS sockets on the Meridian Surround Processor to the DSP loudspeaker you have chosen as the master (typically the centre speaker).
- Use the audio part of the M5 lead to connect the DSP loudspeaker to the C/S digital output on the Meridian Surround Processor.
- Connect an SY-lead to the COMMS output from the master DSP loudspeaker, then connect one of the sockets on the SY lead to one socket on the 511 using an S5 lead.
- Link all the other DSP loudspeakers together in pairs using S5 leads, as shown in the illustration.
- Connect each pair of DSP loudspeakers to the appropriate digital output on the Meridian Surround Processor, using an S5 lead. The other part of the S5 lead is used to distribute the COMMS from the 511 to each pair of DSP loudspeakers.
- Set the digital channel selection switch to position 2 on the subwoofer.

## To connect a subwoofer to a stereo digital source, such as a Meridian CD Player

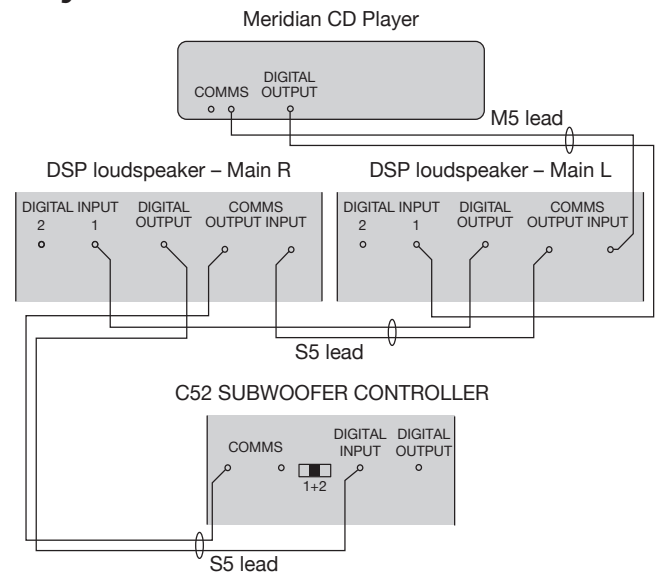

You can connect a pair of DSP loudspeakers and a subwoofer directly to a digital source. The DSP loudspeakers include volume, balance, and tone controls allowing you to control the system using the MSR+.

- Connect the DIGITAL OUTPUT and a COMMS socket from the Meridian source or control unit to DIGITAL INPUT 1 and the COMMS input on the DSP loudspeaker chosen as the master, using an M5 lead.
- Connect the DIGITAL and COMMS outputs from the master DSP loudspeaker to DIGITAL INPUT 1 and the COMMS input on the other (slave) DSP loudspeaker, using an S5 lead.
- Connect the DIGITAL and COMMS outputs from the slave DSP loudspeaker to the DIGITAL INPUT and COMMS on the subwoofer, using an S5 lead.
- Set the digital channel selector switch to position 1+2, to mix the left and right channels to the subwoofer.

## Analogue input connections

Connect the PHONO INPUT MONO to the dedicated subwoofer output of a preamplifier or surround controller, if it is the only subwoofer in the system, or the left or right output of a preamplifier or digital surround processor, if the subwoofer is used as one of a stereo pair.

PHONO INPUT LEFT/RIGHT should be connected to the left and right outputs of a preamplifier or surround processor, if it is the only subwoofer.

XLR BALANCED INPUT (Channel 1/2) should be connected to the dedicated balanced subwoofer output of a preamplifier or surround controller, if it is the only subwoofer in the system, or the left or right XLR output of a preamplifier or digital surround processor with balanced outputs, if the subwoofer is one of a stereo pair.

If you are connecting a single subwoofer to a preamplifier or surround processor with a dedicated subwoofer output, connect that balanced output to the appropriate balanced mono input channel on the C52.

If you are connecting two subwoofers to a system, connect the left channel output to the balanced input of the one C52 channel and the right channel output to the balanced input of the other C52 channel.

The audio connections should be made with high quality audio phono leads or XLR leads.

### To connect a subwoofer to an analogue preamplifier

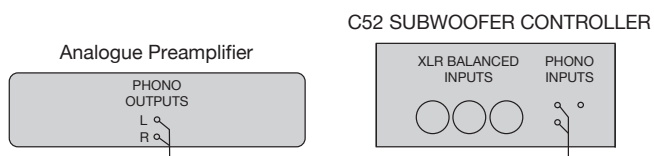

- Connect the analogue outputs from the preamplifier or analogue surround processor to the LEFT and RIGHT phono inputs of the subwoofer. The subwoofer mixes the channels to create a mono signal.
- If your preamplifier provides balanced outputs, use the LEFT and RIGHT XLR BALANCED inputs on the subwoofer instead.

### To connect a stereo pair of subwoofers to an analogue preamplifier

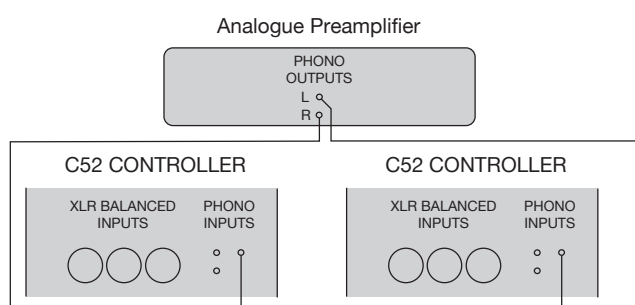

- Connect the left analogue output from the preamplifier to the MONO PHONO INPUT of the left subwoofer.

- Connect the right analogue output from the preamplifier to the MONO PHONO INPUT of the right subwoofer.
- If your preamplifier provides balanced outputs, use the MONO XLR BALANCED input on each subwoofer instead.

## CONFIGURING THE SUBWOOFER

To adjust the C52, remove the smoked acrylic front panel to access the controls. Replace it when configuration has been satisfactorily completed to avoid unintentional adjustment.

### Setting the adjustable low-pass filter

Each channel includes a low-pass filter which can be adjusted between 40Hz and 150Hz, or disabled using the DEFEAT switch.

If you are connecting the subwoofer to a digital surround processor that provides its own crossover, such as a Meridian digital surround processor, set the low-pass filter switch to DEFEAT.

If you are connecting the subwoofer to an analogue preamplifier or surround processor, set the low-pass filter to the middle of its range, and then listen to a sweep tone from the processor if it provides one, or alternatively from a test disc, and make sure the bass is smooth throughout the range.

If there is a peak in the bass loudness, the subwoofer may be adding to the bass from your main speakers, in which case reduce the low-pass filter frequency.

Likewise, if there is a dip in the bass loudness, increase the low-pass filter frequency.

### Setting the gain

The GAIN control allows you to adjust the loudness of the subwoofer to suit the other components in your system.

For the best signal to noise ratio, adjust the level of the subwoofer using the level control on the subwoofer. If you are using a Meridian Digital Surround Processor, you can then use the processor's calibration option to fine-tune the subwoofer level if necessary.

If your surround processor or preamplifier does not include a Calibration option, listen to familiar source materials and adjust the gain until the bass sounds solid and deep, but not boomy or intrusive.

### **Setting the phase (polarity)**

The PHASE switch allows you to invert the phase (reverse the polarity) of the signal to the subwoofer.

If your digital surround processor includes a Calibration option and you can adjust the phase there, set the switch to the + position.

If the bass sounds hollow or phasey, and does not image correctly, change the position of the PHASE switch. If in doubt, select the position that gives the most bass.

When you have completed configuration of the C52, replace the acrylic cover provided, to avoid unintentional adjustment.

## **TROUBLESHOOTING**

### **Unit goes silent when played hard**

The unit has a temperature sensing system on board, which prevents overheating of the electronics. The sound will continue when the speaker has cooled.

### **There is radio interference**

The subwoofer is a digital audio and computing device which has been designed to very high standards of electromagnetic compatibility.

If this equipment does cause or suffer from interference to/from radio or television reception then the following measures should be tried:

- Reorient the receiving aerial (or antenna) or route the antenna cable of the receiver as far as possible from the subwoofer and its cabling.
- Ensure that the receiver uses well-screened antenna cable.
- Relocate the receiver with respect to the subwoofer.
- Connect the receiver and this product to different AC outlets.

- If the problem persists contact your dealer.

### **Drive units move when the C52 is switched on or off**

This is normal as the electronics settle.

### **Subwoofer stays in standby**

This indicates a problem with the Comms setup:

- Check the comms cabling
- Reselect the source and increase or decrease the volume.

### **Subwoofer output sounds odd and lacking in bass when connected to a Meridian digital processor**

A digital audio connection carries two channels. Make sure that you are picking up the right one. For example, if you have connected the subwoofer to the Centre/Sub output of the processor, make sure that the digital input switch is set to 2 to pick up the sub signal. If it is set to 1 you will hear the signal intended for the centre channel.

If the speaker on a channel is configured as *Small* its signal will not contain any bass, and a subwoofer set to pick up that channel will therefore not output much of a signal. Check the subwoofer definitions in the configuration and change as necessary.

---

**Meridian Audio Limited**

Latham Road,  
Huntingdon, Cambridgeshire PE29 6YE  
United Kingdom  
Tel +44 (0) 1480 445678  
Fax +44 (0) 1480 445686

**Web:** [www.meridian-audio.com](http://www.meridian-audio.com)

BOOTHROYD STUART  
**MERIDIAN**<sup>®</sup>

Meridian is registered trademark of Meridian Audio Ltd  
Other trademarks are the property of their respective owners.

**Meridian America Inc**

8055 Troon Circle, Suite C  
Austell, Atlanta GA 30168-7849  
USA  
Tel +1 (404) 344 7111  
Fax +1 (404) 346 7111

**Email:** [info@meridian-audio.com](mailto:info@meridian-audio.com)