



Audio Core 200
User Guide

MERIDIAN

Important safety instructions

- Read these instructions.
- Keep these instructions.
- Heed all warnings.
- Follow all instructions.
- Do not use this apparatus near water.
- Clean only with a dry cloth.
- Do not block any ventilation openings. Install in accordance with the manufacturer's instructions.
- Do not install near any heat sources such as radiators, heat registers, stoves, or other apparatus (including amplifiers) that produce heat.
- Only use attachments/accessories specified by the manufacturer.
- Unplug this apparatus during lightning storms or when unused for long periods of time.
- Refer all servicing to qualified service personnel. Servicing is required when the apparatus has been damaged in any way, such as power-supply cord or plug is damaged, liquid has been spilled or objects have fallen into the apparatus, the apparatus has been exposed to rain or moisture, does not operate normally, or has been dropped.

WARNING: TO REDUCE THE RISK OF FIRE OR ELECTRIC SHOCK, DO NOT EXPOSE THIS APPARATUS TO RAIN OR MOISTURE.

- Use only with the mains power adapter supplied with the unit. Replacements are available from your Meridian dealer.

Safety warnings

- Do not expose the unit to dripping or splashing.
- Do not place any object filled with liquid, such as a vase, on the unit.
- Do not place naked flame sources, such as lighted candles, on the unit.
- To avoid overheating leave at least 10cm around the equipment to ensure sufficient ventilation.
- Do not position the unit in direct sunlight, near heat sources such as a radiator, or directly on top of heat producing equipment, such as a power amplifier.
- To avoid interference do not position the unit near strong electrical or magnetic radiation, such as near a power amplifier.

Radio interference

FCC Warning: This equipment generates and can radiate radio frequency energy and if not installed and used correctly in accordance with our instructions may cause interference to radio communications or radio and television reception. It has been type-tested and complies with the limits set out in Subpart J, Part 15 of FCC rules for a Class B computing device. These limits are intended to provide reasonable protection against such interference in home installations.

EEC: This product has been designed and type-tested to comply with the limits set out in EN55013 and EN55020.



Copyright

Meridian Audio Ltd
Latham Road
Huntingdon
Cambridgeshire
PE29 6YE
England

Copyright © 2010 Meridian Audio Ltd.

Visit us on the Web:
<http://www.meridian-audio.com>

Part no: AC200 (P88393)

This guide was produced by: Human-Computer Interface Ltd,
<http://www.interface.co.uk/>

Unpacking

The Audio Core 200 is supplied with the following accessories:

- Mains power adapter.
- Remote control handset.
- This manual.

If either of these items are missing please contact your dealer.

NOTE: You should retain the packaging in case you need to transport the unit.

Back panel

The following diagram gives details of the back panel connections:

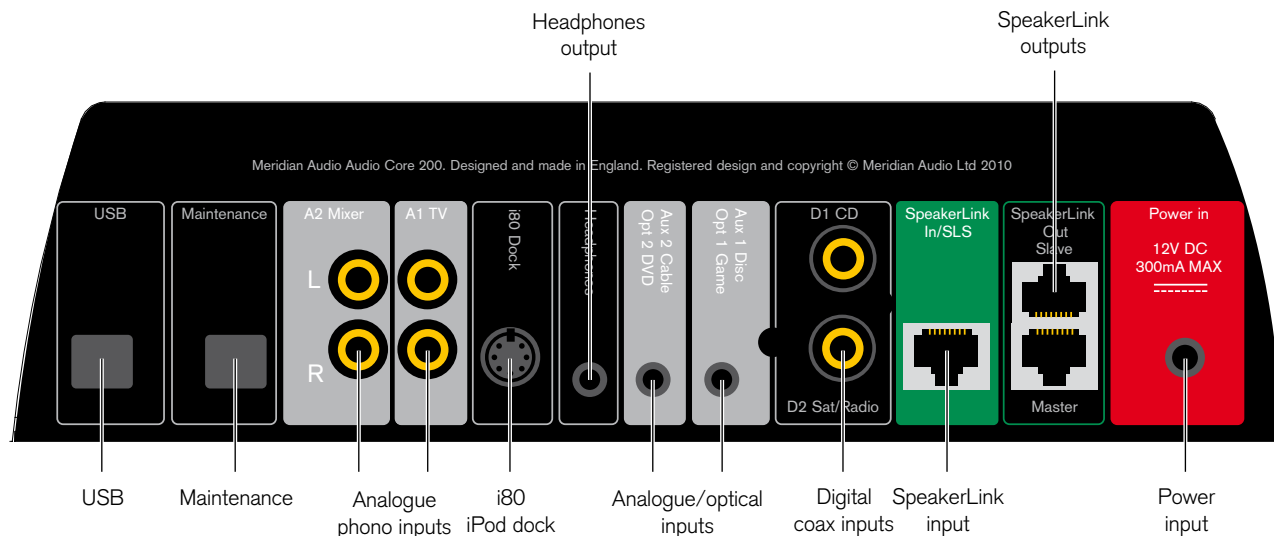

Outputs

Use this output

SpeakerLink Out
Master, Slave
Headphones

To connect to this

Digital loudspeakers, such as DSP3200, using Meridian SpeakerLink leads.
A pair of headphones, terminated with a 3.5mm jack plug.

Analogue inputs

Use this input

A1 TV, A2 Mixer

Aux 1, Aux 2

To connect to this

Analogue sources, using stereo phono leads.
Analogue sources, using stereo leads terminated in a 3.5mm mini jack plug.

Digital inputs

Use this input

D1 CD, D2 Sat/Radio
SpeakerLink In/SLS

To connect to this

Digital sources, using S/PDIF leads.
A Meridian source or Sooloos system with a SpeakerLink output, using a Meridian SpeakerLink lead.

USB

A computer, using a USB cable terminated in a Type B plug, to use the AC200 as an external sound card.

Opt 1 Game, Opt 2 DVD

Digital sources, using optical cables terminated in 3.5mm optical jack plugs (same sockets as Aux 1 and Aux 2).

i80 Dock

An iPod mounted in a Meridian i80 dock, with control of the iPod from the AC200 front panel.

Applications

To connect a pair of Meridian DSP loudspeakers

The Audio Core 200 can be connected directly to a pair of Meridian DSP loudspeakers, such as the DSP3200, to make an ideal compact system.

- Connect the lower SpeakerLink output on the Audio Core 200 to the master DSP loudspeaker, using a Meridian SpeakerLink lead.
- Connect the upper SpeakerLink output on the Audio Core 200 to the slave DSP loudspeaker, using a Meridian SpeakerLink lead.

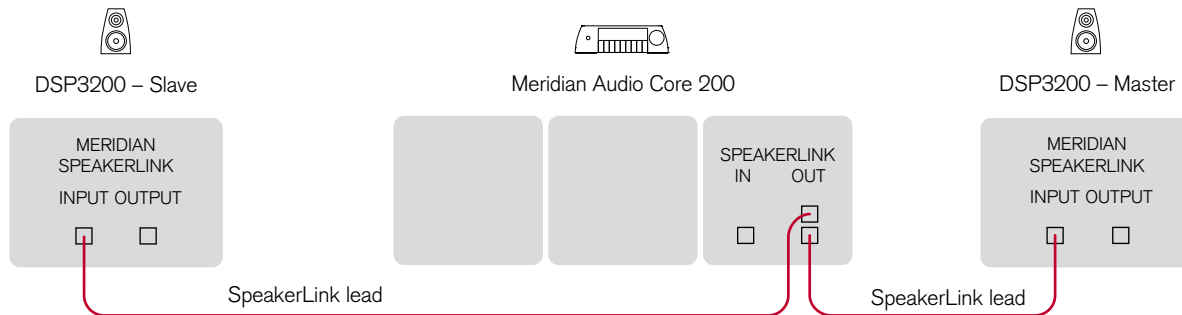

To connect to a PC

The Audio Core 200 allows you to play digital media directly from a PC, for high-quality reproduction of music and film soundtracks.

If your PC provides a digital optical output:

- Connect the digital optical output to the Audio Core 200 Opt 1 (or Opt 2) optical input, using an optical cable terminated in a 3.5mm optical jack plug.

- Set the **SLink** option to **On** in the Audio Core 200 **Speakers** setup menu.

If you are using DSP3200s make sure the Channel selector is set to the L/C position on the back of the left speaker and to the R position on the back of the right speaker.

For other DSP loudspeakers configure the master DSP loudspeaker as **M.RJ45** and the slave DSP loudspeaker as **S.RJ45**; see the *DSP Loudspeaker User Guide*.

- Select the Game (or DVD) input on the Audio Core 200.

If your PC provides a USB output:

- Connect the USB output to the Audio Core 200 USB input, using a USB cable terminated in a Type B plug.
- Select the USB input on the Audio Core 200.

To connect to a Sooloos system

The Audio Core 200 makes an ideal control unit for a Meridian Sooloos Digital Media System, based on a Control 15 or a Media Core 200.

- Connect the Control 15 or Media Core 200 SpeakerLink output to the Audio Core SpeakerLink input, using a Meridian SpeakerLink lead.

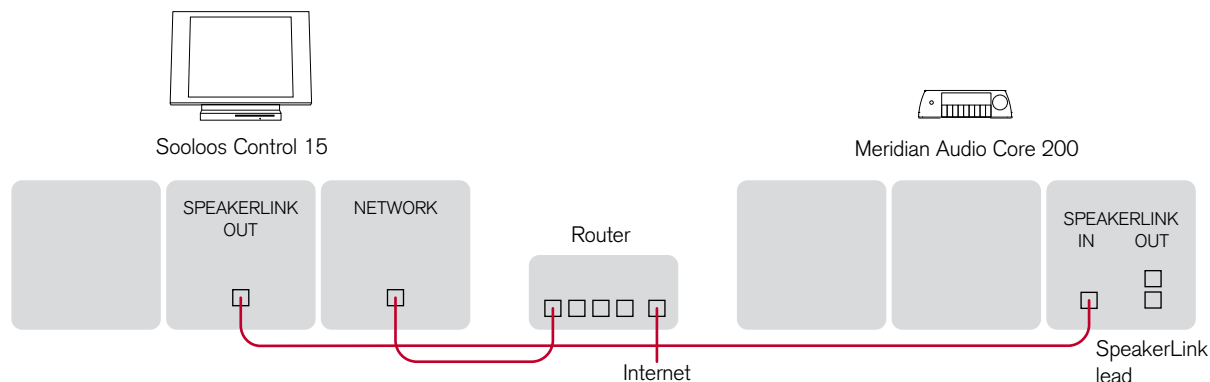

- Select the SLS input on the Audio Core 200.

You can control the volume from the Sooloos Control 15, from one of the various Meridian Sooloos control applications, or using the volume control on the Audio Core 200.

To connect headphones

The Audio Core 200 includes a headphone output for listening with or without the speaker outputs.

- Connect the headphones to the headphones output.

- To mute the speakers when headphones are connected set the **Speakers** option to **Mute** in the **Headphone** setup menu.
- To use headphones which have their own integral volume control set the **Level** option to **Fixed** in the **Headphone** setup menu.

Front panel

The following diagram gives details of the front panel controls:

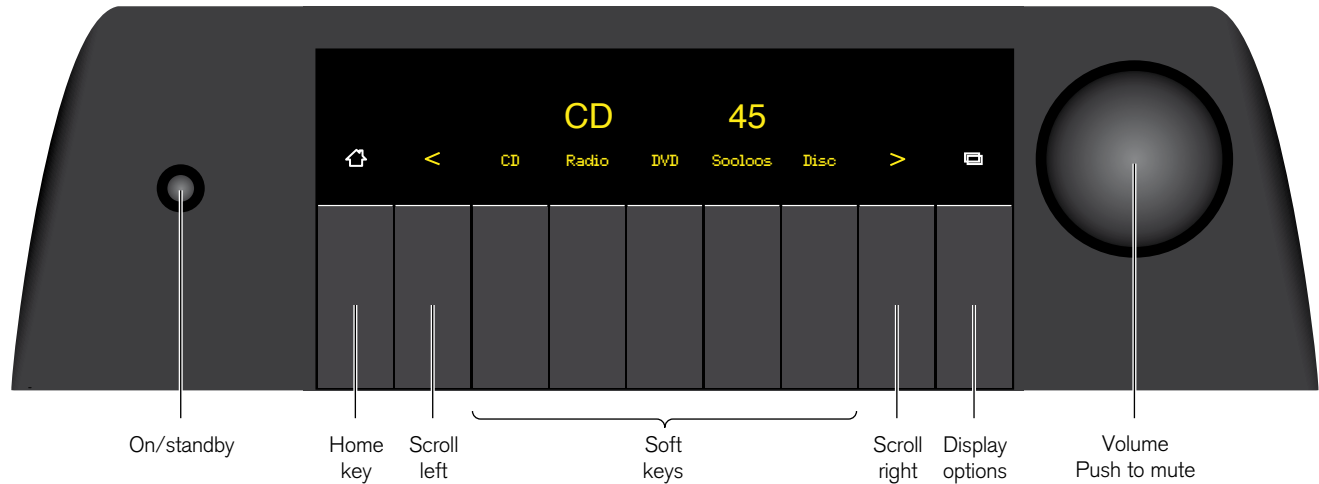

On/standby

Switches the Audio Core on, or to standby.

Home

Displays the Home set of soft keys for selecting a source. Press > to see more sources.

Scroll left <

Displays the previous set of soft keys. From the Home keys this gives the **Setup** and **Audio** options.

Soft keys

Allow you to select a source, or a **Setup** or **Audio** option. The current functions are shown on the bottom line of the display.

Scroll right >

Displays the next set of soft keys.

Display

Blanks the display.

Volume

Turn to adjust the volume, or push to mute the sound. The current source and volume are shown on the display.