A large, stylized, grey letter 'M' is centered on a black background. The letter is composed of thick, solid grey strokes. In the central negative space of the 'M', the words 'user guide' are written in a white, lowercase, sans-serif font, oriented vertically from bottom-left to top-right.

user guide

Meridian 558 Multi Channel Power Amplifier

Meridian 558 Multi Channel Power Amplifier User Guide

Sales and service in the UK

Meridian Audio Ltd
Stonehill
Stukeley Meadows
Cambs
PE18 6ED
England

Tel (01480) 52144
Fax (01480) 459934

World Wide Web
<http://www.meridian-audio.com>

Sales and service in the USA

Meridian America Inc
3800 Camp Creek Parkway
Building 2400
Suite 122
Atlanta
GA 30331

Tel (404) 344 7111
Fax (404) 346 7111

Designed and manufactured in the UK by

Digital Gramophone and Wireless Ltd
Stonehill
Stukeley Meadows
Cambs
PE18 6ED
England

Copyright © 1993–2000 Digital
Gramophone and Wireless Ltd

Part no: 557/1

This guide was produced by
Human-Computer Interface Ltd,
<http://www.interface.co.uk>

Contents

Introduction 1

Introduces the 558 Multi Channel Power Amplifier, and provides an overview of the other products available in the Meridian 500 Series.

The Meridian 500 Series	2
Sample configurations	3
Specification and accessories	4

Setting up the multi channel power amplifier 5

Describes how to unpack, install, and use the multi channel power amplifier, and explains what you should do if it requires servicing.

Unpacking	6
Connecting the multi channel power amplifier	7
Connecting a source	10
Connecting speakers	11

Troubleshooting 15

Provides suggested solutions to typical problems.

Troubleshooting	16
Maintenance	17
Service and guarantee	18
Index	19



Introduction

The 558 Multi Channel Power Amplifier provides five discrete power amplifiers in a single enclosure, and is ideal for multi-channel surround systems. Two pairs of channels can also be operated in bridge mode, for over twice the power output.

The 558 Multi Channel Power Amplifier uses a unique feedback topology and precision local error correction system. It includes two massive twin wound toroidal transformers, and the unit has full thermal, load, and DC protection on every output.

Each of the five channels provides either balanced or unbalanced inputs, and these can be selected individually.

This guide is designed to enable you to obtain the best possible results from the unit in conjunction with the other units in your system.

The Meridian 500 Series

The Meridian 500 Series is a unique system of digital, analogue, and video components designed to meet the demand for absolute quality, ease of use, and lasting value.

The flexibility of the Meridian 500 Series is such that you can assemble a system as simple or as complex as you need, perfectly suited to your musical and environmental requirements, and with the ability to add to it or change it at a later date should your requirements change. The 500 Series is also compatible with the existing Meridian 200 Series and 600 Series components.

Each Meridian 500 Series component is housed in a matching slim line case. Front panel controls provide access to the most important functions, and the full range of functions is available from the Meridian System Handset using a simple and intuitive control interface.

500 Series communications

The Meridian 500 Series includes a sophisticated communications link, to ensure that any configuration of units will work together as a fully integrated system.

The 500 Series communications system allows you to control any combination of units using a single remote, and ensures that your commands from the remote are interpreted unambiguously. The communications system also allows you to extend your hi-fi system into two or three rooms, with the ability to control the sources in one room from the controller in another room.

Professional features

The 500 Series also provides features for professional users, including RS232 computer control, and balanced connections.

The following pages give a sample configuration illustrating the flexibility of the Meridian 500 Series.

Sample configuration

558 Multi Channel Power Amplifier

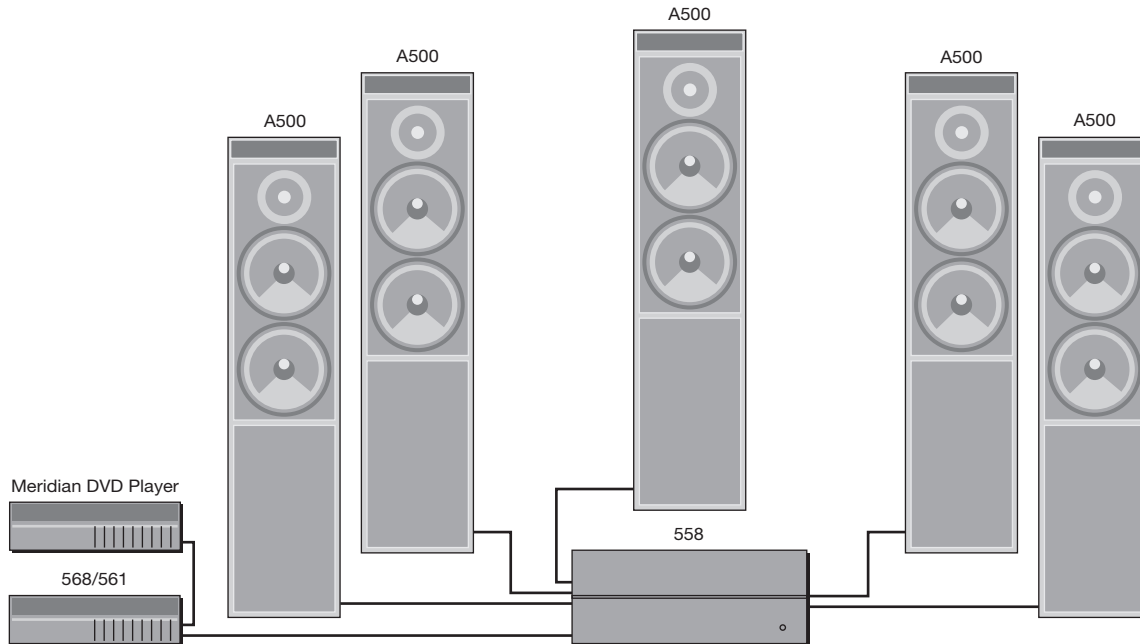

The 558 Multi Channel Power Amplifier is ideal for use with the Meridian 561 Digital Surround Controller or the 568 Digital Surround Processor, to drive five analogue loudspeakers in a high-quality surround system. The 568 provides balanced

outputs from the front left, right, and centre channels, and so is ideal for use with the balanced inputs of the 558 Multi Channel Power Amplifier.

Specification and accessories

Specification

Input	1.4V RMS.
Output (bridged mode off)	Greater than 200W per channel into 8Ω. Greater than 300W per channel into 4Ω.
Output (bridged mode on)	Greater than 400W into 8Ω. Greater than 600W into 4Ω.
Distortion	Less than 0.05%.
Noise	Less than -90dB.
Trigger input	5 to 30Vdc or 5-30Vac peak to peak, polarity independent.
Finish	Black textured enamel and brushed aluminium.
Dimensions	442mm x 174mm x 450mm (17.4" x 6.8" x 17.7") (W x H x D).
Weight	50kg.
Consumption	30VA quiescent, 1200VA max.

Meridian Audio reserves the right to amend product specifications at any time.

Available accessories

The following accessories are available from your dealer:

- Power cord Europe.
- Power cord Canada and USA.

Rack mount kit

The Meridian 500 Shelf is a tray produced by Middle Atlantic Products which will allow the 558, or any other 500 Series unit, to be fitted in a standard 19" rack. For more information please contact Middle Atlantic products, Inc., Riverdale, NJ 07457, USA, (001) 973-839-1011, or their local distributor.

Setting up the multi channel power amplifier

This chapter explains how to install the multi channel power amplifier. It describes what you should find when you unpack the multi channel power amplifier, how you should connect it to your other audio equipment, and the siting constraints.

You should not make any connections to the multi channel power amplifier or to any other component in your system whilst the AC power supply is connected and switched on.

Unpacking

The 558 Multi Channel Power Amplifier comes in a box containing the following components:

- 558 Multi Channel Power Amplifier.
- 1 power cord.
- 2 bridged mode links.
- This manual.

You are advised to retain the packing in case you need to transport the unit.

The 558 Multi Channel Power Amplifier weighs 50kg. Do not attempt to lift it without assistance.

Before connecting power

Before you begin installation you should ensure that your multi channel power amplifier is set to the correct voltage for your local AC supply. If it is not, do not try to install the unit, and contact your dealer.

Do not make connections, or insert or remove plugs, while the unit is connected to the supply and switched on, as the transients generated could damage the loudspeakers.

To position the multi channel power amplifier

During normal operation the internal heatsinks may become quite hot. The multi channel power amplifier should therefore be positioned to allow a free flow of air through the cooling vents from the base to the top.

Do not place the multi channel power amplifier:

- In direct sunlight.
- Near heat sources, eg a radiator.
- Stacked with any other audio products, as the heat it generates may damage the other products.

Do not restrict airflow through the top and bottom vents.

Connecting the multi channel power amplifier

Back panel

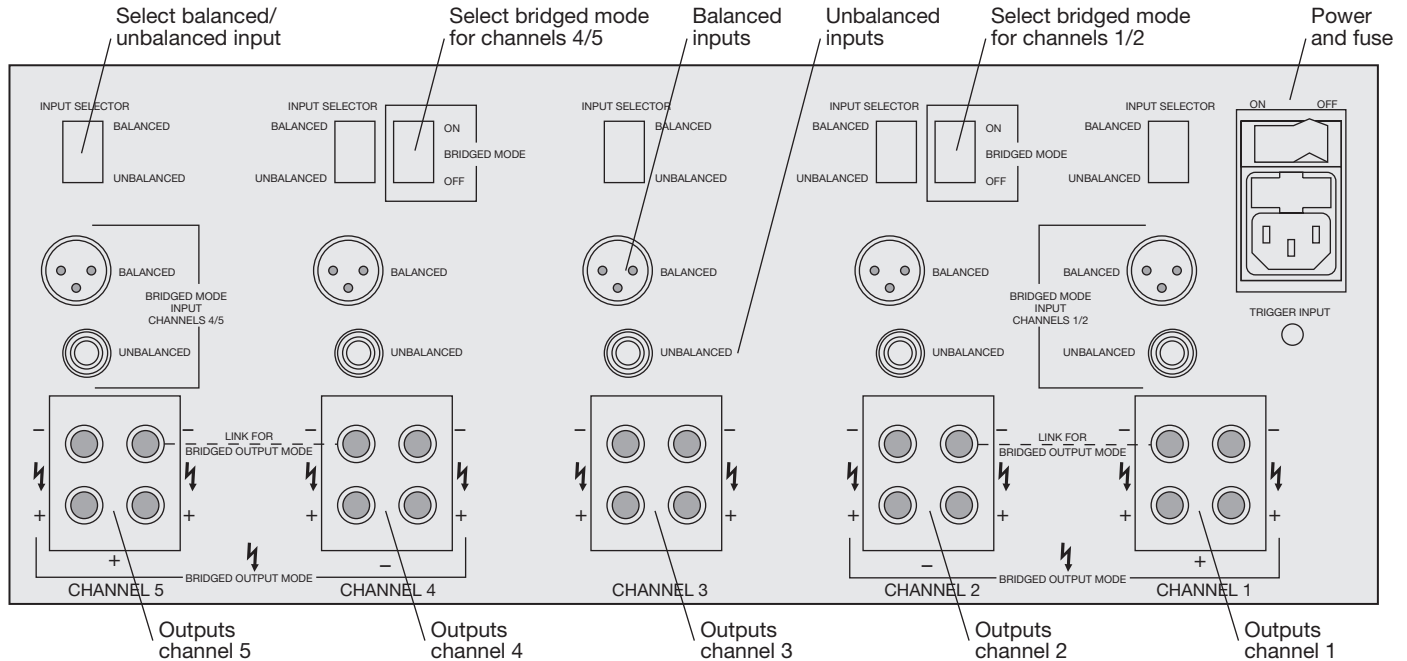

Outputs

The following table gives details of the output connections:

<i>Use this output</i>	<i>To connect to this</i>
CHANNEL 1 to CHANNEL 5	Loudspeakers of 4Ω to 15Ω, using either plug or bare wire connections.

The recommended assignment of channels, to make best use of the capacity of each power supply, is as follows:

<i>Channel</i>	<i>Assignment</i>
CHANNEL 1	Main left
CHANNEL 2	Main right
CHANNEL 3	Centre
CHANNEL 4	Rear left
CHANNEL 5	Rear right

Alternatively, channels 1/2 and 4/5 can be used in bridged output mode; see *To wire to A500 Loudspeakers in bridged mode*, page 12.

Each channel of the 558 Multi Channel Power Amplifier provides twin outputs for bi-wiring. On speakers that provide separate

connections to the bass/mid and tweeter units this allows the units to be connected independently to the multi channel power amplifier, for optimum sound quality.

Alternatively, for loudspeakers providing a single pair of inputs, either of the output terminals can be used.

Inputs

The following two alternative audio inputs are provided for each channel:

<i>Use this input</i>	<i>To connect to this</i>
UNBALANCED	A preamplifier, using phono connectors and high-quality screened cable.
BALANCED	A balanced analogue output, using XLR connectors: <ul style="list-style-type: none"> 1 (Green) = GND 2 (Red) = +ve 3 (Black) = -ve

Select the appropriate input using the INPUT SELECTOR for each channel.

Standby

Once set up, the multi channel power amplifier can be left in standby as it consumes negligible power in this mode.

To bring the amplifier out of standby press the button on the front panel. Alternatively, the 558 can be brought out of standby automatically using the TRIGGER INPUT; see below.

If you are not going to use the multi channel power amplifier for a period of several days you should switch the unit completely off, at the back panel, and disconnect it from the AC power supply.

Trigger input

The TRIGGER INPUT can be used to bring the multi channel power amplifier out of standby by applying a signal from a control unit.

The trigger input should be an AC or DC signal of between 5 and 30V. Suitable trigger signals are provided by the Meridian 561, 562, 568, 800, or 861.

Connecting a source

To connect to an analogue preamplifier (eg Meridian 501/501V)

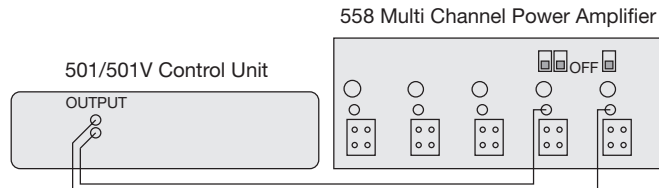

- Switch the BRIDGED MODE switch for channels 1/2 to the OFF position.
- Connect the sockets marked UNBALANCED on the back panel of the multi channel power amplifier to the outputs from your preamplifier.
- Switch the INPUT SELECTOR switches for the corresponding channels to the UNBALANCED position.

You should either use a twin-screened audio cable, or a pair of single-screened audio cables. These cables can have a considerable effect on the quality of the sound, and you are advised to seek your dealer's advice on the best type of cables for your system.

To connect to a 568 Digital Surround Processor

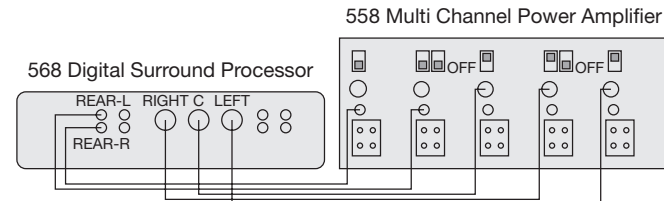

- Switch the two BRIDGED MODE switches to the OFF position.
- Connect the LEFT, RIGHT, and CENTRE balanced outputs from the 568 to the CHANNEL 1, 2, and 3 BALANCED inputs on the 558.
- Switch the INPUT SELECTOR switches for CHANNEL 1, 2, and 3 to BALANCED.
- Connect the REAR-L and REAR-R phono outputs from the 568 to the CHANNEL 4 and 5 UNBALANCED inputs on the 558.
- Switch the INPUT SELECTOR switches for CHANNEL 4 and 5 to UNBALANCED.

Connecting speakers

To connect to A500 Loudspeakers

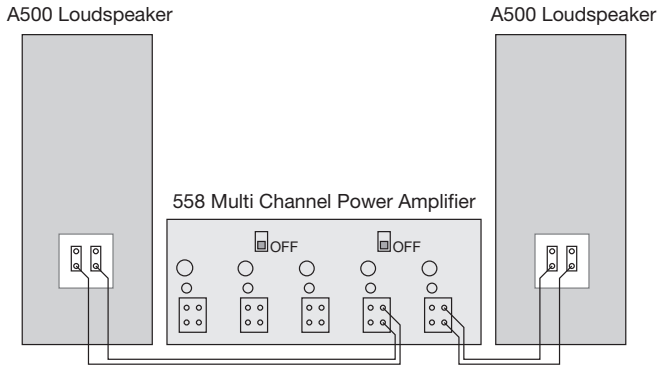

- Set the BRIDGED MODE switches to the OFF position.
- Connect one of each pair of the red and black terminals from the appropriate channel of the 558 Multi Channel Power Amplifier to the red and black terminals on the A500 Loudspeakers.

To bi-wire to A500 Loudspeakers

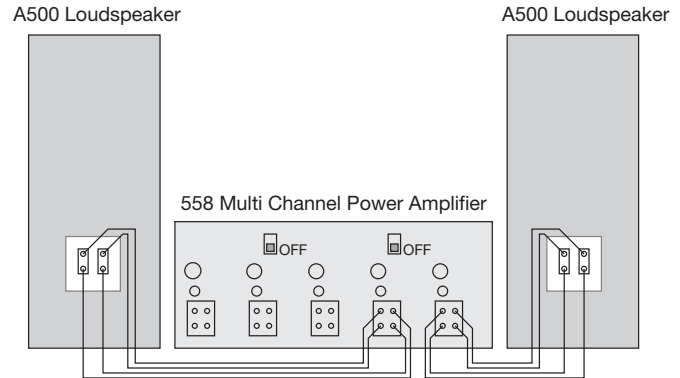

- Set the BRIDGED MODE switches to the OFF position.
- If necessary, remove the links bridging the LF and HF terminals on the back of each loudspeaker.
- Connect the LF red and black terminals from each loudspeaker to the red and black terminals on the appropriate channel of the multi channel power amplifier, using twin loudspeaker cable.
- Connect the HF red and black terminals from each loudspeaker to the other pair of red and black terminals on the appropriate channel of the multi channel power amplifier.

To wire to A500 Loudspeakers in bridged mode

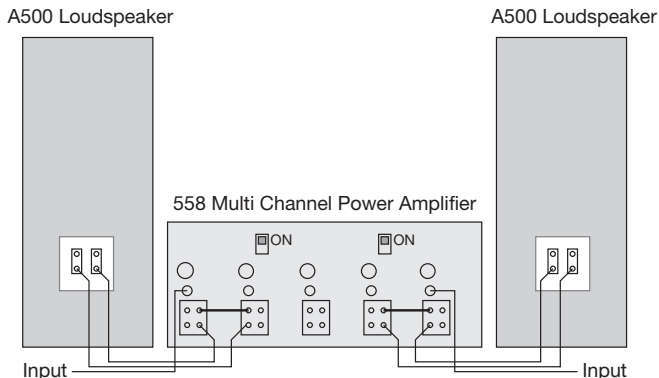

You can wire channels 1/2 and 4/5 in bridged output mode, to obtain more than twice the power output.

- Switch the BRIDGED MODE switches to the ON position.
- Connect the audio inputs to the BALANCED or UNBALANCED CHANNEL 1 and CHANNEL 5 inputs, as appropriate.

- Connect the supplied bridged mode links between the black (-) CHANNEL 1/2 and CHANNEL 4/5 terminals, as marked on the back panel.
- Connect the loudspeakers between one pair of the red (+) CHANNEL 1/2 and CHANNEL 4/5 terminals.

You can bi-wire in bridged mode by using the other pair of red terminals to connect separately to the loudspeaker treble unit.

To bi-amp to two A500 Loudspeakers

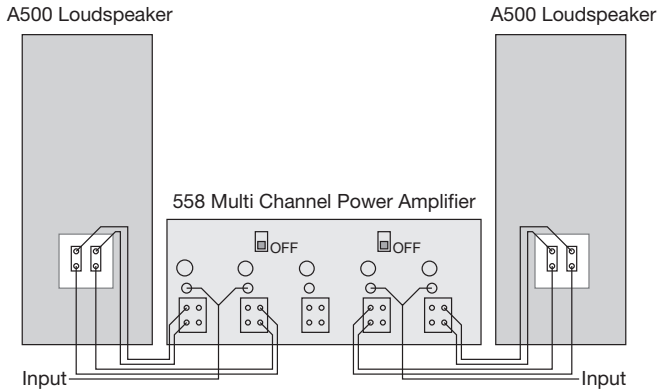

Extremely high sound quality can be achieved using two separate channels of the multi channel power amplifier to drive the LF and HF units in each loudspeaker.

- Switch the BRIDGED MODE switches to the OFF position.
- Connect the left audio output from the preamplifier to both inputs on channels 1 and 2.
- Connect the right audio output from the preamplifier to both inputs on channels 4 and 5.

- If necessary, remove the links bridging the LF and HF terminals on the back of each loudspeaker.
- Connect the red and black terminals from the LF and HF units on the left loudspeaker to the red and black terminals on channels 1 and 2.
- Likewise, connect the LF and HF units from the right loudspeaker to channels 4 and 5.

To connect two 558s to a seven-channel surround system

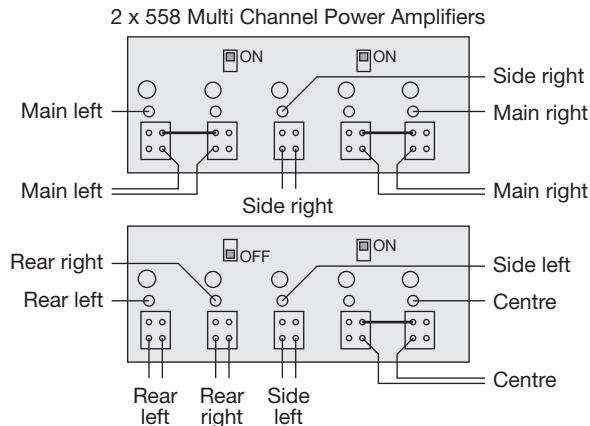

Two 558 Multi Channel Power Amplifiers can be used as the basis of a superb seven-channel surround system, taking advantage of bridged mode operation to give more than twice the power output for the three front channels.

- Switch channels 1/2 and 4/5 of the first 558 to bridged mode, and use these for the main left and right loudspeakers.

- Switch channels 1/2 of the second 558 to bridged mode, and use these for the centre loudspeaker.
- Use the remaining channels for the side and rear loudspeakers, as shown in the diagram.

Troubleshooting

This chapter provides suggested solutions to typical problems that may occur when setting up or using the multi channel power amplifier.

If you are still not able to resolve a difficulty with the help of this guide and the suggestions in the following pages, please contact your Meridian dealer or Meridian Audio Ltd.

Troubleshooting

No front panel indicator is shown

- Check that your AC power supply is connected correctly.
- Check that the **ON OFF** switch on the back panel is in the ON position.
- Check that the unit has been taken out of standby using the front panel button or TRIGGER INPUT.
- Check that the fuse on the multi channel power amplifier back panel and the fuse in the unit's power plug have not blown; see *To change the mains fuse*, page 17.

The sound has cut out

The 558 Multi Channel Power Amplifier includes a thermal shutdown, which mutes the output if the amplifier becomes too hot. The Standby LED will also become red.

- Leave the amplifier for a few minutes to cool down, the Standby LED will turn green and the sound will come back on.

The 558 Multi Channel Power Amplifier also includes a power circuit breaker to protect the loudspeakers. This is also triggered if the mains supply is interrupted.

- Check the system for the cause of the cut out.
- Switch off, wait 5 seconds, then switch on to reset the power.

Maintenance

Cleaning

When cleaning the multi channel power amplifier bear in mind that the front of the unit is brushed aluminium and the case is metal.

Disconnect the power cord before cleaning the unit.

Note: Do not use abrasive cleaners on any part of the multi channel power amplifier.

To clean the case

- Use a slightly damp cloth.

Ensure that no water is allowed to get inside the case, and do not reconnect the power until you are certain that the multi channel power amplifier is completely dry.

To clean the audio connections

The audio sockets on the back of the multi channel power amplifier are gold-plated and need no cleaning if gold-plated phono plugs are used. Otherwise, it is recommended that you unplug and reconnect the plugs at least once a year. A proprietary contact cleaner can be used to some advantage.

To change the mains fuse

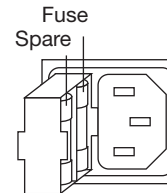

- Remove the mains connector, and pull out the drawer next to the power input to access the fuses.

Before replacing a blown fuse, if possible ascertain the cause of the failure.

The fuse drawer includes a spare fuse. This should be replaced by one of the same rating.

Service and guarantee

Service

The Meridian 500 Series of hi-fi components have been carefully designed to give years of untroubled service. There are no user-serviceable parts inside the case, nor do the units require any form of maintenance.

In the unlikely event that your multi channel power amplifier fails to function correctly, it should be returned, in its original packaging, to your Meridian dealer.

In case of difficulty within the UK or USA please contact the appropriate sales and service address shown on page ii.

In case of difficulty outside the UK or USA, contact the importing agent for the territory. A list of Meridian agents abroad is available from Meridian Audio.

No responsibility can be accepted for the multi channel power amplifier whilst in transit to the factory or an agent, and customers are therefore advised to insure the unit.

When seeking service under guarantee, proof of the date of purchase will be required.

Guarantee

The 558 Multi Channel Power Amplifier is guaranteed against defects in material and workmanship for two years from the date of purchase.

The guarantee is void if the 558 Multi Channel Power Amplifier has been subject to misuse, accident, or negligence, or has been tampered with or modified in any way without the written authorisation of Meridian Audio Limited. Attempted servicing by unauthorised people may also invalidate this guarantee. Labour and carriage charges are not covered unless by local agreement.

Outside the UK, local warranty liability is restricted to equipment purchased within the territory. Our agents abroad are only under contractual obligation to service under guarantee equipment sold through them. They are entitled to make a non-refundable charge for any service carried out on other equipment.

This guarantee does not limit your statutory rights within the United Kingdom.

Index

- A Accessories** 4
- B Balanced inputs** 8
 - Bi-amp connection** 13
 - Bi-wire connection** 8, 11
 - Bridged mode** 12
- C Cleaning** 17
 - the audio connections 17
 - the case 17
 - Components** 6
 - Connecting**
 - to a 501/501V Control Unit 10
 - to a 568 10
 - to A500 Loudspeakers 11, 12
 - to an analogue preamplifier 10
 - to two A500 Loudspeakers 13
 - two 558s to a seven-channel surround system 14
- F Fuse, replacing** 17
- G Guarantee** 18
- H Heat generated during operation** 6
- I Inputs** 8
 - Installing** 6
 - Introduction** 1
- L Lifting the 558** 6
 - Loudspeakers, connecting** 8
- M Maintenance** 17
 - Meridian 500 Series** 2
 - 568 Digital Surround Processor 3
 - communications 2
 - Meridian System Handset** 2
- O Outputs** 8
 - Overheating** 6, 16
- P Positioning** 6
- S Service** 18
 - Seven-channel surround system** 14
 - Sound has cut out** 16
 - Specification** 4
 - Switching on** 9
- T Thermal protection** 16
 - Trigger input** 9
 - Troubleshooting** 15
- U Unbalanced inputs** 8
 - Unpacking** 6
- X XLR connectors** 8

