



DSP730 IN-WALL DIGITAL ACTIVE LOUDSPEAKER USER GUIDE



Important safety instructions



- Read the instructions.
- Keep these instructions.
- Follow all instructions.
- Do not use this apparatus near water.
- Clean only with a dry cloth.
- Install only in accordance with the manufacturer's instructions. Refer all servicing to approved service personnel.

WARNING: TO REDUCE THE RISK OF FIRE OR ELECTRIC SHOCK, DO NOT EXPOSE THIS APPARATUS TO RAIN OR MOISTURE.

This apparatus has been designed with Class 1 construction and must be connected to a mains socket outlet with a protective earthing connection (the third grounding pin).

This apparatus uses a single-pole power switch. As a result it is not isolated from AC mains power when switched off at the rear panel. The apparatus may be isolated from mains power either by unplugging the power connector from the rear of the unit, or by unplugging the connector at the opposing end of the power cord or cable from its supply outlet. As a result, either or both of these connectors should remain accessible.

Safety warnings

	WARNING! RISK OF ELECTRIC SHOCK - DO NOT OPEN ATTENTION! NE PAS OUVRIR - RISQUE DE DÉCHARGE ÉLECTRIQUE	
---	---	---

Caution: to reduce the risk of electric shock, do not remove cover. No user serviceable parts inside. Refer servicing to qualified service personnel.



The lightning flash with arrowhead symbol, within an equilateral triangle, is intended to alert the user to the presence of uninsulated “dangerous voltage” within the product’s enclosure that may be of sufficient magnitude to constitute a risk of electric shock to persons.



The exclamation point within an equilateral triangle is intended to alert the user to the presence of important operating and maintenance (servicing) instructions in the literature accompanying the appliance.

Climate

The equipment has been designed for use in moderate climates and in domestic situations.



Only use at an altitude not exceeding 2000m.

Safety warnings

- Do not expose the unit to dripping or splashing.
- Do not place any object filled with liquid, such as a vase, on the unit.
- Do not place naked flame sources, such as lighted candles, on the unit.

To avoid overheating

- Do not position the product in direct sunlight.
- Do not position the product near heat sources, such as a radiator.
- Leave at least 10cm around the product to ensure sufficient ventilation.

Radio interference

FCC Warning: This equipment generates and can radiate radio frequency energy and if not installed and used correctly in accordance with our instructions may cause interference to radio communications or radio and television reception. It has been type-tested and complies with the limits set out in Subpart J, Part 15 of FCC rules for a Class B computing device. These limits are intended to provide reasonable protection against such interference in home installations.



EEC: This product has been designed and type-tested to comply with the limits set out in EN55032:2015 and EN55024:2010 + A1:2015.

IP20 EQUIPMENT

Copyright and acknowledgements

Sales and service

All direct support for Meridian products, systems and associated software is provided through our authorised distribution network. If you require any such advice or information, you should contact your Meridian dealer.

Designed and manufactured in the UK

Meridian Audio Ltd, Latham Road, Huntingdon, Cambridgeshire, PE29 6YE, England.

Meridian Audio reserves the right to make changes and improvements to any of the products described in this document without prior notice.

Copyright © 2025 Meridian Audio Ltd.

Part no: P88488/5

Visit us on the Web

www.meridian-audio.com

Product registration

Register your DSP730 In-Wall Digital Active Loudspeaker at:
meridian-audio.com/register



Contents

Introduction	1
Specifications	3
Installing the DSP730	4
Front and back panel	9
Setting up the DSP730	11
Configuring the loudspeaker using the IR eye	13
RS232 control and configuration	14

Introduction

The new-for-2026 DSP730 is precision-engineered in Britain to deliver scalable, reference-grade performance for architectural and cinema applications.

The DSP730 emerged from Meridian's Extreme Engineering Programme, the same initiative that produced the DSP8000 XE. It brings Meridian's most advanced technologies and design principles to the architectural category, combining powerful, precise performance with the visual discretion demanded by modern installations.

As one of the reference models in Meridian's in-wall range, it delivers the full Meridian experience, engineered for both music and film, where fidelity, control and scale must integrate seamlessly into any environment.

Designed, engineered and hand-built in the United Kingdom, the DSP730 reflects Meridian's enduring commitment to British craftsmanship and innovation in sound.

The DSP730 can be combined with a Meridian in-wall subwoofer to produce a full-range, two-box solution.

Acoustic enclosure

The DSP730 features a sealed "double-baffle" aluminium enclosure design which minimises unwanted resonances and colouration to ensure a reliable and repeatable performance in every installation. The enclosure also acts as a heatsink with huge thermal capacity for the built-in power amplifiers. A separate mid-range driver enclosure prevents the bass driver from interacting with the mid-range unit. The tweeter features a custom steel waveguide which maximises frequency response and contributes to the loudspeaker's excellent dispersion characteristics.

New Command board

This brand-new board design carries the loudspeaker's digital electronics hardware. This includes a new DSP engine supporting '4x' sampling rates, allowing up to 192 kHz signals through the entire digital audio path. The loudspeaker features thirteen of Meridian's proprietary DSP technologies, with DSP headroom to accommodate potential future developments. A lower noise-floor contributes to a higher dynamic range, while new DACs further improve sound-quality.

2 DSP730 In-Wall Digital Active Loudspeaker *User Guide*

Image Elevation

As LED screens and large-format displays become increasingly popular in premium living spaces, integrators often face the challenge of keeping dialogue locked to the centre of the screen when speakers are positioned below it. Meridian's Image Elevation technology solves this problem by using advanced psychoacoustics to raise the perceived sound source, so voices appear to come directly from the screen.

Image Focus Plus

This technology provides two adjustable settings. A 'delay balance' control uses gains and delays to correct for a listening position which is off-centre in the horizontal (left-right) plane, so a realistic sonic image can be achieved even when sitting closer to one or other of the speakers in a pair. In addition, an 'axis' control applies the same principles to the vertical plane by adjusting the sound from the tweeter relative to the mid-range driver of each speaker. This enables compensation to be made for the height of the speakers relative to the listener. The sound can be steered up or down, so the perception is that the tweeter is at the ideal 'ear-height'.

Construction

The DSP730 is designed to have an elegant profile, with only 102mm installation depth.

It is made up of a narrow, self-contained, all-metal enclosure with a metal mounting frame. Its purpose-built rough-in wall box is available separately.

The rough-in box is first fitted to the wall, the frame is mounted to it, and the loudspeaker enclosure is then bolted to the frame. The rough-in box and frame can be adjusted for various wall materials and depths. The frame is designed for mounting into new-build partition and stud style walls, or for retrofitting into stud or brick/stone-built walls.

A male-to-female IEC mains lead is supplied with the loudspeaker in order to connect it to the rough-in box, which is wired to power.

The paintable, perforated steel grille supplied with the loudspeaker can be fitted where required. The grille is held in place by powerful rubber-coated magnets which are attached to the aluminium extrusion that forms the front panel of the loudspeaker enclosure.

Controlling the loudspeaker

The loudspeaker can be controlled in three ways:

- In most installations, the loudspeaker will be controlled by another Meridian product within the system.
- Alternatively, the loudspeaker features an infra-red receiver which allows it to be controlled using a Meridian System Remote.
- Thirdly, the loudspeaker can be controlled using RS232 commands.

Specifications

Audio input

- 1 x Meridian SpeakerLink connector (RJ45)

Audio output

- 1 x Meridian SpeakerLink connector (RJ45)

Drivers

- Tweeter: Aluminium dome with custom steel waveguide
- Mid-range: 1 x 100mm
- Bass: 1 x 100mm

Amplifiers

- Three pairs of Class-D amplifiers – each pair bridged, capable of delivering over 100W into 8Ω

Performance

- Peak SPL: 115dB @ 1m
- Frequency response 38Hz to 40kHz

Front panel

- Switch selects Right, L+R, or Left or Centre
- IR receiver eye
- LED indicators show power status and configuration settings

Physical

- Dimensions: 800mm* x 203mm x 102mm (31.5"* x 8.0" x 4.0") (H x W x D)
- Weight: 11kg (24.2lb)
- Grille dimensions: 819.5mm x 222.5mm x 4mm (36.2" x 8.73" x 0.16") (H x W x D)

* Excluding frame and cable feed channel

Power

- IEC mains lead supplied to connect loudspeaker enclosure to rough-in box
- 500W max
- This product is available factory pre-set in the following voltage options: 100V AC 50-60Hz, 110-120V AC 50-60Hz and 220-240V AC 50-60Hz

Installing the DSP730

The loudspeaker is designed to be fitted in a Meridian wall box type RF500. If necessary, refer to the *RF500 Wall Box Installation Instructions*:

meridian-audio.com/RF500-installation

Contents

Each DSP730 loudspeaker is supplied with the following components:

- Mounting frame.
- Mains cable.
- M5 x 25mm clamping screws – 8 pieces.
- M5 x 10mm lock screws – 6 pieces.
- M5 x 20mm guide-in screws – 8 pieces.
- Grille.
- Grab handle.
- 3mm Allen key (hex wrench)
- 4mm Allen key (hex wrench)
- Grille extractor tools – 2 pieces.

The mounting frame is fitted to the wall box prior to fitting the loudspeaker.

The grab handle can be used to help with lifting the loudspeaker into position.

1. Prepare for installation

- Remove the mounting frame; it is packed underneath the loudspeaker within the packing carton.
- Remove the grab handle; it is packed in one of the foam packing pieces within the carton.

2. Fit the grab handle

- Insert the grab handle into the available holes either side of the tweeter (see illustration below).
- Rotate it so it locks into position.

Note: the grab handle is not suitable to use when installing the loudspeaker horizontally.

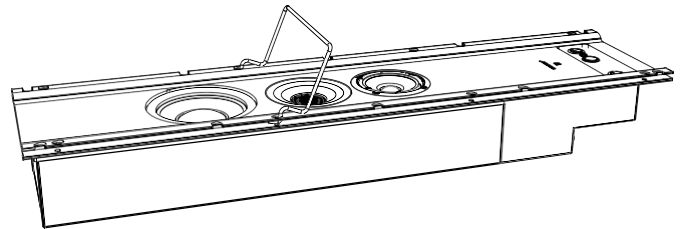

3. Fit the mounting frame

- Slide the mounting frame into the wall box.
- Clamp the frame to the wall with the M5 x 25mm button-head clamping screws (8 pieces).

After tightening these screws for a few turns you will feel resistance due to the shakeproof nylon inserts in the wall box. Tighten these screws only until the frame is secure without being distorted. The shakeproof inserts ensure that the screws will hold the loudspeaker in place without rattling or shaking loose – even at high volume levels.

If the frame is bent even slightly out of true, the screws and holes may not line up correctly with the threaded holes, making the screws difficult to fit.

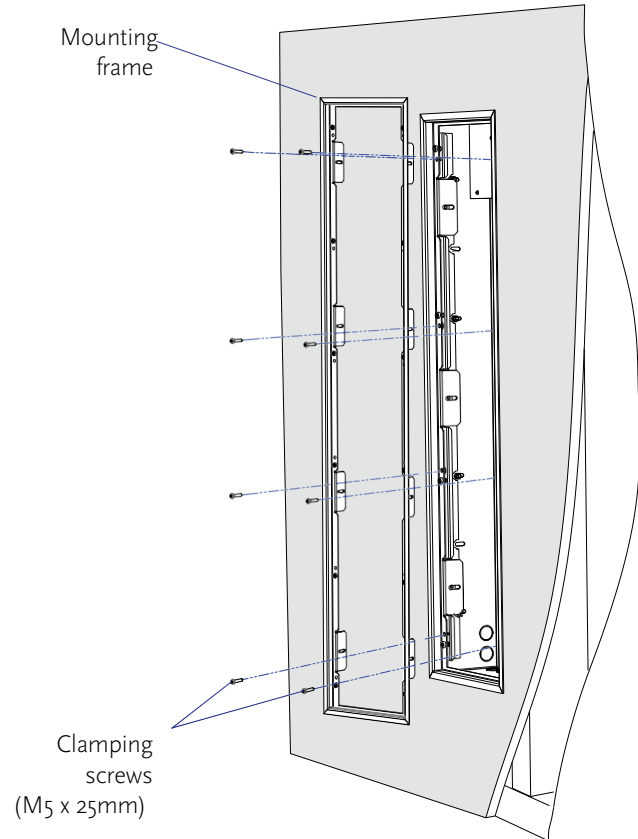

4. Lock the frame into place

Once the frame is tight against the wall:

- Lock into place with M5 x 10mm button-head lock screws (6 pieces).
- Lock tight.

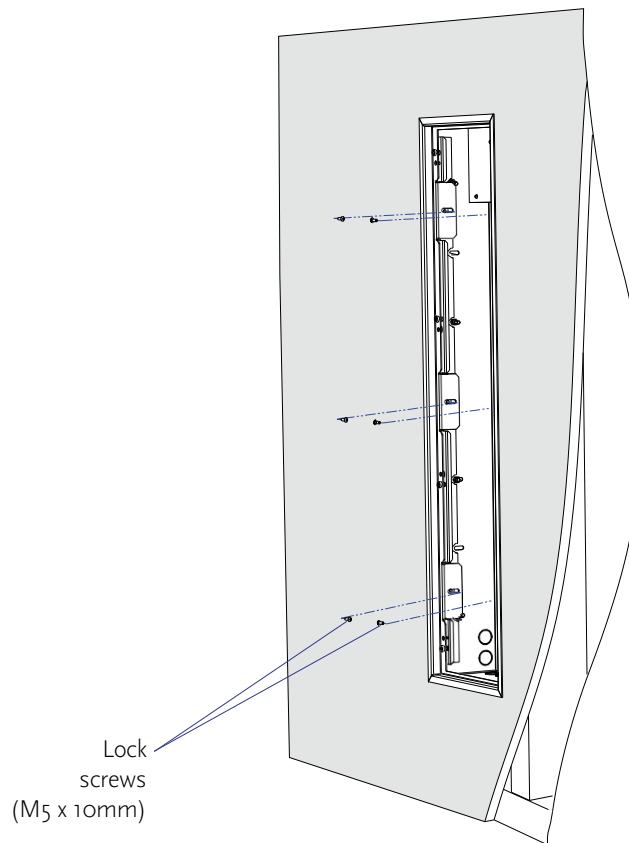

5. Fit the loudspeaker

- Using the grab handle, sit the loudspeaker on the lower edge of the wall box.
- Plug in the RJ45 cable(s) and AC supply.
- With the aid of the grab handle, slide the loudspeaker into position, inserting the top of the loudspeaker into the wall box first.
- Fix with M5 x 20mm guide-in screws (8 pieces).
- Remove the grab handle to fit the last pair of screws. This is no longer required.

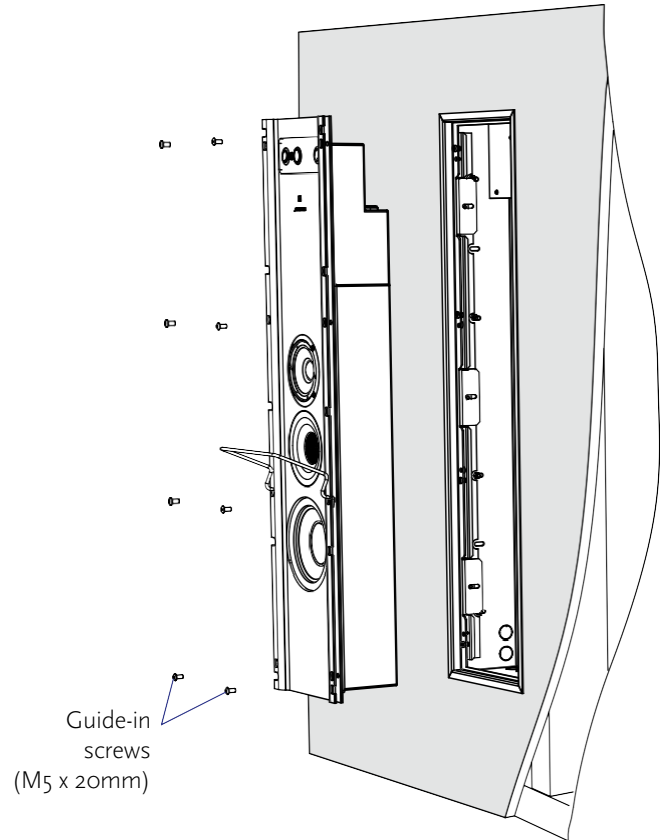

6. Fit the grille

- Carefully hold the grille with your fingers at the top,
- Locate the lower edge of the grille at the bottom edge of the mounting frame for alignment.
- Lay the grille gently down onto the magnets, which will hold it in place.

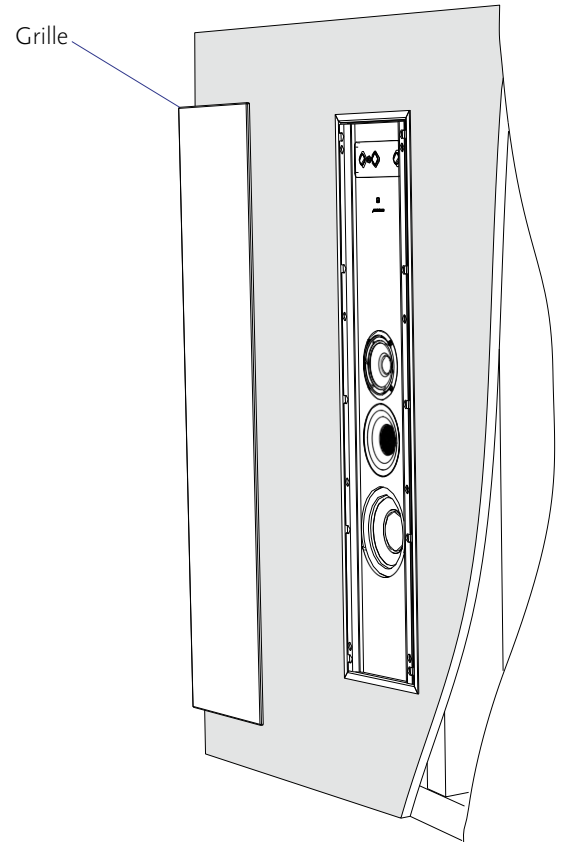

Front and back panel

Connections

The following diagram gives details of the connections on the back of the loudspeaker:

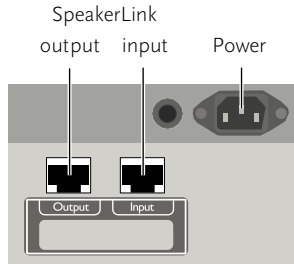

Use this connection	To connect to this
SpeakerLink input	The SpeakerLink output of a Meridian controller or another loudspeaker when connecting in a daisy-chain.
SpeakerLink output	The SpeakerLink input of another loudspeaker when connecting in a daisy-chain.
Power	The RF500 wall box power output using the supplied plug-in mains cable.

Front panel

The following diagram gives details of the front panel:

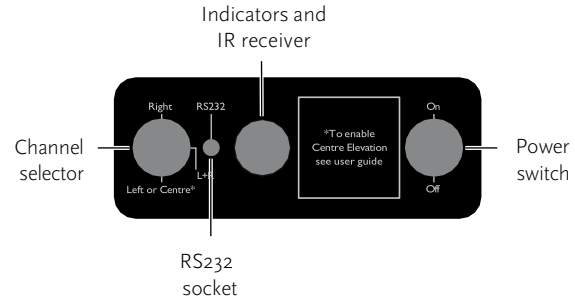

Item	Description
Channel selector	Specifies the loudspeaker's role in the system. See <i>Setting up the DSP730</i> , page 11.
RS232 socket	Allows you to configure the loudspeaker. See <i>RS232 via the front-panel socket</i> , page 16.
Power switch	Controls the mains supply to the loudspeaker.

10 DSP730 In-Wall Digital Active Loudspeaker *User Guide*

Status indicators

Status	Description
Steady blue	Loudspeaker in standby.
Steady white	Loudspeaker operating.

For an explanation of the configuration status indicators see *Configuring the loudspeaker using the IR eye*, page 13.

Setting up the DSP730

This section explains how to set up the loudspeaker in each of the typical applications.

Using the loudspeaker on the left of the system

- Set the channel selector switch to **Left** or **Centre**.

In a multichannel system this applies to all loudspeakers on the left-hand side of the room

Using the loudspeaker on the right of the system

- Set the channel selector switch to **Right**.

In a multichannel system this applies to all loudspeakers on the right-hand side of the room

Using a single loudspeaker individually with a TV

- **Set the channel selector switch to L+R.**

If the loudspeaker is located below the display screen Image Elevation can be used to raise the sound image up to the screen.

- Choose between **Off** (lowest), **Minimum**, **Medium**, or **Maximum** (highest).

The ideal setting will depend on the layout of the loudspeaker and screen.

When the channel selector switch set to **L+R** Image Elevation can be adjusted via RS232; see *RS232 control and configuration*, page 14. The setting will be retained even if the loudspeaker is powered off.

Image Elevation is only appropriate for loudspeakers located below the display screen, or the mid-height point of an acoustically transparent screen. It may be of limited benefit if the distance between the loudspeaker and the screen is small relative to the distance between the screen and the listening position.

Using the loudspeaker to play a mix of left and right audio in other situations

- Set the channel selector switch to **L+R**.

This will play a balanced mix of left and right audio, allowing a single loudspeaker to reproduce all the audio present in a stereo recording. It also provides a useful option for systems using multiple speakers where the listening area does not have clearly-defined left and right loudspeaker positions.

12 DSP730 In-Wall Digital Active Loudspeaker *User Guide*

Using the loudspeaker as a centre channel

- Set the channel selector switch to **Left or Centre**.

If the loudspeaker is below the display screen Image Elevation can be used to raise the sound image up to the screen.

- Choose between **Off** (lowest), **Minimum**, **Medium**, or **Maximum** (highest).

The ideal setting will depend on the layout of the loudspeaker and screen.

As well as improving the sense of dialogue coming from centre stage, Image Elevation can enhance the integration of sounds that pan from left and right in a multichannel system.

When set to **Left or Centre**, the loudspeaker needs to have **Centre mode** activated in order to make Image Elevation available. This can be done using a Meridian System Remote as described in *Configuring the loudspeaker using the IR eye*, page 13, or via RS232 as described in *RS232 control and configuration*, page 14.

In Centre mode:

If the system features a suitably-equipped Meridian controller product, Image Elevation can be adjusted via the menu system of the controller product. Check the user guide of the controller product to see whether it supports the Image Elevation menu and how to adjust it.

Regardless of the other equipment in the system, Image Elevation can be adjusted via RS232. The setting will be retained even if the loudspeaker is powered off, so the optimal setting can be chosen at the time of installation as a one-off operation.

Image Elevation is only appropriate for loudspeakers located below the display screen, or the mid-height point of an acoustically transparent screen. It may be of limited benefit if the distance between the loudspeaker and the screen is small relative to the distance between the screen and the listening position.

Configuring the loudspeaker using the IR eye

Some settings can be changed by sending commands from a Meridian System Remote (not supplied) directed at the IR eye while powering-up the loudspeaker. The status of the setting is indicated by flashing indicators behind the lens of the IR eye immediately after the operation.

Centre mode

Centre mode can be toggled off and on by holding down the Left-cursor key (<) while powering-up the loudspeaker.

Status	Description
White indicator flashes four times	Centre-mode activated.
Blue indicator flashes four times	Centre-mode deactivated.

Factory reset

A factory reset can be performed by holding down the **Stop** key while powering-up the loudspeaker. The white indicator flashes three times, showing the loudspeaker has been reset.

* For systems featuring a Meridian surround controller product, refer to the controller's user guide for how to identify the Master loudspeaker.

IR control

The loudspeaker can be controlled using infra-red commands from a Meridian System Remote (MSR2, MSR+ or MSR). However, this feature needs to be activated; by default, the loudspeaker will not respond to IR commands.

Only a 'Master' loudspeaker can have its IR reception activated. In a two-channel system, the Master can be identified as the loudspeaker connected to the Master socket on the Controller product.*

The IR receiver can be activated in three different ways:

- Auto IR Set-up – with the Master loudspeaker in Standby mode, press the 'Clear' key on the Meridian remote while pointing it at the loudspeaker's IR eye.
- By sending a command to the Master loudspeaker via RS232 (see page 14 of this guide).
- By storing a configuration setting from a Meridian B-Link Bluetooth adapter (available separately) which is connected to the Master loudspeaker.

RS232 control and configuration

For the full list of RS232 commands for Meridian loudspeakers, refer to Meridian TechNote TN51. This covers non-volatile settings relating to installation options as well as standard control commands to be used by third-party control systems.

Centre mode, Image Elevation, HPA and IR control status

The commands used for Centre mode, Image Elevation, HPA (High Power Array) and IR control status are detailed here as these features most often generate the need to use RS232 with the loudspeaker.

Centre mode

The RS232 commands related to Centre mode are as follows:

Command	What it does
valueSet Cm ON	Activates Centre mode.
valueSet Cm OFF	Deactivates Centre mode.
valueSet Cm	Returns current status of Centre mode.

When the channel selector switch is set to **L+R** Centre mode is activated by default; otherwise, it is deactivated by default.

Image Elevation

The RS232 commands to adjust Image Elevation are as follows:

Command	What it does
valueSet IE SL	Enables control of Image Elevation by commands over SpeakerLink.*
valueSet IE OFF	Switches Image Elevation off.*
valueSet IE MIN	Sets Image Elevation to Minimum.
valueSet IE MED	Sets Image Elevation to Medium.
valueSet IE MAX	Sets Image Elevation to Maximum.

* By default, the loudspeaker is set to valueSet IE SL and Image Elevation will remain set to off until it is changed by a valid command over SpeakerLink.

HPA (High Power Array)

The RS232 commands related to HPA mode are as follows:

Command	What it does
valueSet AR PRI	Set as 'Primary' speaker within the HPA
valueSet AR SEC	Set as 'Secondary' speaker within the HPA
valueSet AR OFF	Turn off HPA processing

IR control status

The RS232 commands related to IR control are as follows:

Command	What it does
valueSet CT AUTO	Sets IR control status to Automatic
valueSet CT CON	Sets IR control status to Controller
valueSet CT NCON	Sets IR control status to Not Controller

RS232 connection options

The loudspeaker can receive RS232 commands via the socket on its front-panel or via the SpeakerLink input socket on the back of the loudspeaker. As described on page 16, their respective locations make the two connections suitable for particular use-cases.

RS232 commands

Port settings

9600 Baud, 8 data bits, 1 stop bit, no parity, no flow control

Command format

RS232 commands consist of ASCII characters which are case sensitive. Some commands require parameters, so these are followed by additional characters. All commands are terminated with a carriage return.

Non-volatile configuration

The RS232 commands described in this document produce non-volatile (lasting) configuration changes in the loudspeaker. These commands should be used carefully because they may affect the sound and operation of the loudspeaker without giving any obvious external indications.

16 DSP730 In-Wall Digital Active Loudspeaker *User Guide*

RS232 via the front-panel socket

The front-panel RS232 allows you to configure the loudspeaker to suit its role in the system, or perform firmware updates.

A cable suitable for connecting to the front-panel RS232 socket, terminated in a female DB9 plug, is available from authorised Meridian dealers: Meridian part number: PA10824

The socket accepts the longer version of the three-way, 3.5mm (Qi inch) minijack plug, eg Schurter part no. 4802.1300:

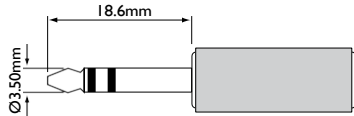

The standard minijack plug commonly used on headphones and ear-buds with a shorter 14mm plug cannot be used:

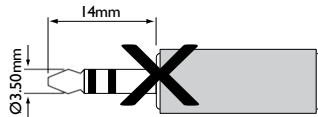

RS232 via the SpeakerLink input

If the loudspeaker is installed behind a projection screen or under a fabric wall-covering, the front-panel RS232 socket may be inaccessible. In this case the SpeakerLink input cable, which

also carries RS232 connections, can be used to configure the loudspeaker.

- Temporarily disconnect the SpeakerLink cable from the product feeding the loudspeaker.
- Connect the RJ45 plug into an RJ45 Inline Coupler to provide an RJ45 socket.
- Connect the RJ45 socket to an RJ45 to RS232 cable.

An RJ45 to RS232 cable, terminated in a female DB9 plug, is available from authorised Meridian dealers: Meridian part number SK1622.

Where loudspeakers are daisy-chained, access to the SpeakerLink input of the downstream loudspeakers can be provided by routing all SpeakerLink feeds through RJ45 couplers located in the rack.

Connections

The two cables use the following connections for RS232:

Function	Female DB9	Minijack	RJ45
RS232 Tx.	3	Ring	6
RS232 Rx.	2	Tip	3
Ground	5	Shield	5



MERIDIAN AUDIO LTD

E: info@meridian.co.uk
T: +44 (0)1480 445678
meridian-audio.com

Designed and engineered in England by Meridian Audio Ltd.

MERIDIAN® and the Meridian 'M' logo® are registered trademarks of Meridian Audio Ltd.

Copyright© 2025 and Design Right 2025 Meridian Audio Ltd. All rights reserved.

